

Talon-2

3D GPR Data Acquisition Software

User Manual

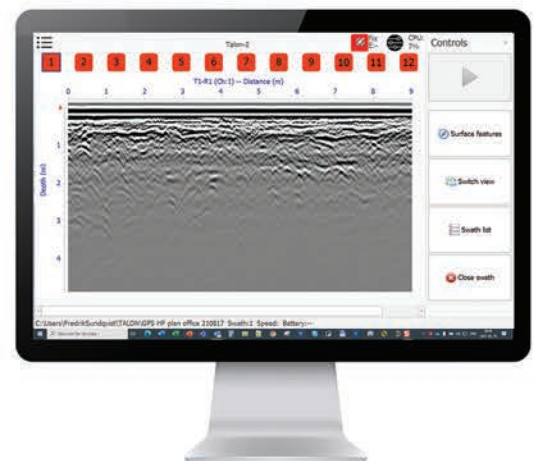

Document information
Manual version: 2026-01
Software version: 1.05.05 or later

© Copyright 2025, ImpulseRadar Sweden AB
Skolgatan 22, Malå, 93931
Sweden
www.impulseradargpr.com

All rights reserved

About this manual/overview

The Raptor® antennas are state-of-the-art, self-contained GPR-systems. The electronic and mechanical design combined with the flexible firmware makes them configurable for a variety of different applications. This manual provides information on the data acquisition software, Talon-2, when antennas are configured for 3D-Mapping, in so called, GPR-arrays¹⁾. For information on other applications, please contact our sales team.

Talon-2 is a completely new development vs the earlier version Talon-1, both may still be used with our arrays system, so no one is forced to upgrade. However, switching between the versions requires firmware upgrades/downgrades and use of the earlier version will not have access to the extended quality control/assessment functionality present in Talon-2.

For information on applications and configurations not covered in this document, please contact our support team at support@impulseradar.se or a certified agent.

ImpulseRadar makes a clear distinction between GPR-Arrays and other multi-channel configurations. With an Array we mean a system with multiple GPR-channels designed for effective gathering of 3D-data suitable for true 3D-processing. The following characteristics are essential in such systems:

- Channel separation in the order of centre-wavelength/4, equal throughout the array.
- Balanced/equalized signatures from all channels
- Similar polarization throughout the array.

Table of Contents

1	Introduction.....	4
1.1.1	Software overview.....	4
1.1.2	System overview.....	4
1.1.3	Conventions.....	5
1.1.4	Requirements.....	6
1.1.5	Installation.....	7
1.1.6	Receiver requirements.....	7
2	Quick start.....	8
2.1.1	Hints/notes during data collection.....	9
3	Start screen.....	10
3.1.	Main Application Menu.....	10
3.1.1	Preferences.....	11
3.1.2	Surface feature definitions.....	12
3.1.3	Channels.....	13
3.1.4	Wheels.....	15
3.1.5	Firmware.....	18
3.1.6	Indicator panel.....	19
3.1.7	Creating a New Project.....	20
3.1.8	Connecting the array.....	20
1.1.	Trace view.....	21
3.1.9	New project/Project overview.....	24
3.1.10	Changing data acquisition parameters.....	25
4	Data acquisition.....	31
4.1.	Project start screen.....	31
4.1.1	Keyboard shortcuts during data acquisition.....	32
4.1.2	Data acquisition controls.....	33
4.1.3	Swath list.....	34
4.1.4	Positioning system status window.....	34
4.1.5	Radargram view.....	35
4.1.6	Map view.....	35
5	Appendix 1: Coordinates for channel set-up.....	37
6	Appendix 2: LED-codes.....	38
7	Appendix 3: Files and file-formats, naming conventions.....	39
8	Appendix 4: Troubleshooting.....	40
9	Appendix 5: Total station set-up.....	42
10	Appendix 6: Firewall Settings.....	44

1 Introduction

1.1.1 Software overview

Talon is a Windows software which controls and acquires data from Raptor systems and connected GPS/Total Station units. It's a pure data acquisition software, with user interface designed for touch-enabled devices, for all field functions. Controls and functionality are optimized for field use, meaning that in all parts of the software relating to data acquisition, screen visibility and QA/QC of incoming data are highest priority. Talon-2 does not provide any data management functionality for further processing. For those stages, please refer to our software's ViewR and Condor.

Talon-2 works with projects. All data files necessary for later data processing/interpretation are stored in a unique folder. Project and folder names, default settings for data acquisition and display as well as other settings are controlled through the preference settings that may be tailored by the user.

Realizing, once back in office, that data is corrupt/useless is a gumption-robbing experience we want to save our clients from. Consequently, the software design is aimed at quality control and quality assessment of GPR- and positioning-data during acquisition. The user will be notified if the data acquisition does not work as expected, such as missing data for a channel, or lost GPS signal. This goal of Talon-2, to help the client collect high quality data, in various environments, has led us to, sometimes, by-pass common windows conventions.

1.1.2 System overview

To better understand error messages and troubleshoot them, it's a helpful to understand just what and how software controls the GPR-array and acquire the data. In Figure 1, below, pictures of a typical 8-ch Raptor system as well as a block schematic of a generic Raptor-system are shown.

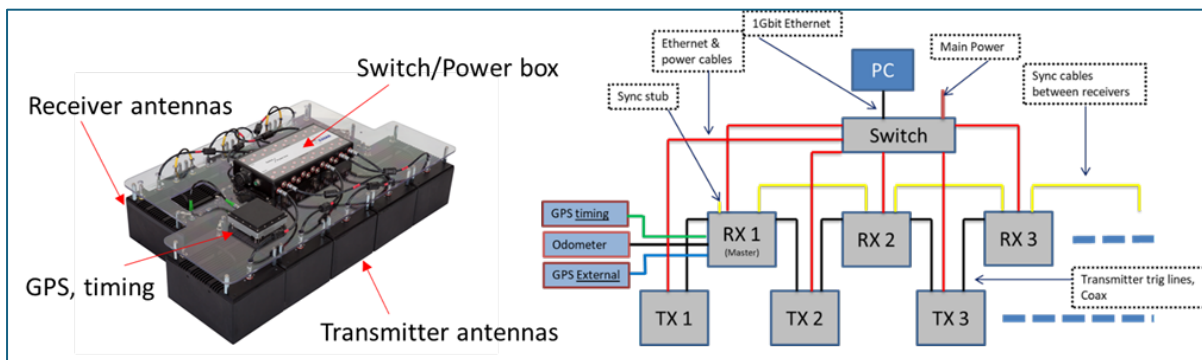

Figure 1 An 8 channel Raptor-45 system (left) and a generic block diagram of a Raptor system (right)

Referring to Figure 1:

Talon-2 is installed in the PC which communicates with each receiver antenna in the array system through a 1Gbit ethernet switch. The switch housing also contains power distribution

for the receivers and transmitters. Prior to data acquisition, Talon-2 identifies each receiver's position in the array, from left to right, and sends the data parameters, sampling frequency and time-window/depth to all receivers.

Each receiver, except the leftmost and rightmost, is connected, through trig-cables to two transmitter antennas. Each receiver may thus collect two channels of GPR-data, except those on the edges.

One, and one only, of the receiver antennas must be configured as a master. The master controls the data acquisition speed, dependent on parameters it gets from Talon-2. Further, the master may be connected to:

- GPS for timing purposes (also called internal GPS). From this GPS the master deducts precise time information on all collected data, for later synchronization with precision GPS data.
- GPS for positioning (also called External GPS), this is a precision GPS (RTK) with centimetre precision. Note that this GPS may also be connected to the PC running Talon-2.
- Odometer wheel, based on information from Talon-2 the master controls the distance between every data-collection spot, also named the point-distance.

Every connected Receiver-Transmitter pair forms a data channel and Talon-2 must know precisely how these channels are positioned with respect to the GPS-Antenna used for positioning (or prism, in the case a total station is used). This information as well as information on whether some channels are inactivated can be found in the channel configurations window and is stored in a separate file for use by data processing software.

The odometer counts tics; hence Talon-2 must know how long distance one tic represents, and in what direction the wheel spins. This is what constitutes a wheel calibration, typically different for all vehicles.

Talon-2 will report failure of any unit and cable in the system, except for the Transmitters and cables connecting the transmitters. Failure of transmitters or cable connecting them can only be seen in the respective radargram or trace view.

Note: The external GPS may also be connected directly to the PC, especially when collecting positions for surface features, this is favourable.

1.1.3 Conventions

This section lists the conventions used in this document, as well as the Talon-2 GUI.

User interface control colours

Colours throughout the user interface of fields and indicators will change dependent on actual status of the underlying parameters/data. The conventions used are:

- Red: Error. Signals an error or something which needs immediate attention.
- Yellow: warning. This doesn't need immediate attention but should be noted to get the best data acquisition possible.
- Green: Ok. No actions are required.

1.1.4 Requirements

For TALON-2 to control and acquire data from Raptor systems, the firmware and hardware present in that system must meet some minimum requirements. TALON-2 will show a message if these requirements aren't met, upgrades can then be managed through the software.

Talon-2 requires a PC with minimum Windows-10, 8GB-ram, SSD-storage and an ethernet port. If data interpretation software is to be run on the same PC, we recommend at least 500GB storage space.

Note: Talon-2 cannot control an array which has receivers with firmware for Talon-1 and vice versa. Talon-2 can upgrade and downgrade firmware's regardless of present version, Talon-1 cannot upgrade or downgrade an array configured for Talon-2.

Communication set-up/link option

For the software to communicate with the Raptor-system the PC Ethernet interface must be set to static IPv4 address:

10.10.255.252 with IPv4 mask: 255.255.0.0. This is done in the windows settings->Network & internet and then Ethernet Interface Settings as shown in Figure 2. Talon-2 will display a message if no ethernet interface is found with the correct address.

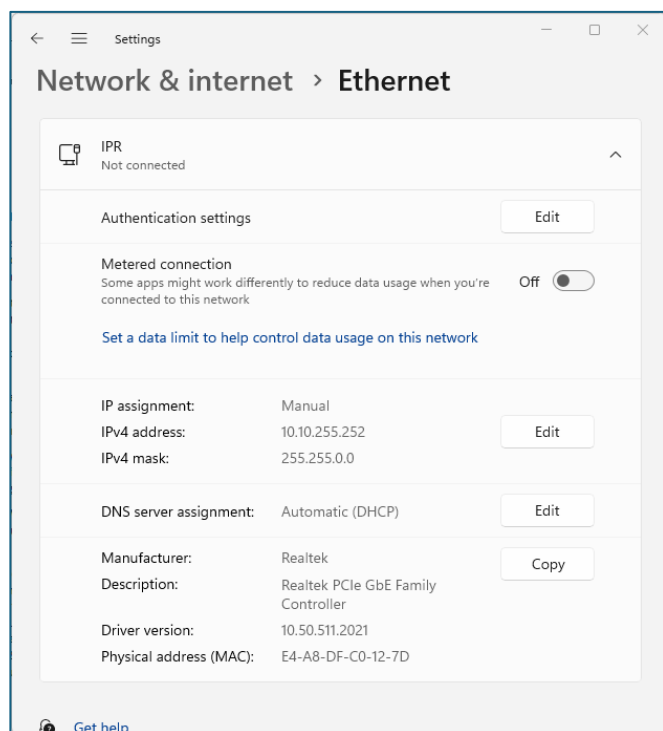

Figure 2 Ethernet interface settings

1.1.5 Installation

To install Talon-2, run the provided installer and follow to installer guide. See Figure 3.

When TALON-2 is installed, existing channel or wheel configurations from the original TALON are not ported to TALON-2. TALON-2 comes with a set of standard channel configurations and wheels. It is easy and straightforward to add and configure your own channel configurations or wheels though.

1.1.6 Receiver requirements

Any receiver used together with Talon-2 must comply with a minimum required firmware version. When receivers with a firmware version not supported are detected, a warning message is shown as seen in Figure 4 below.

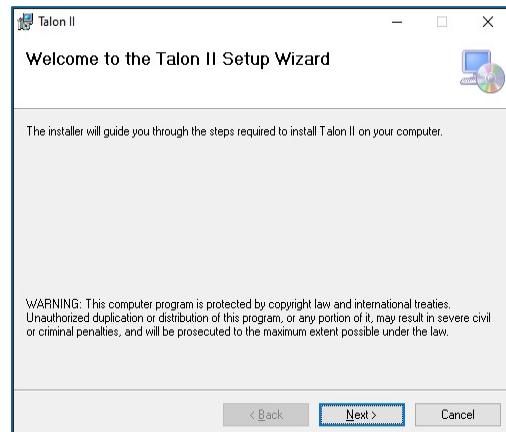

Figure 3 Installer wizard

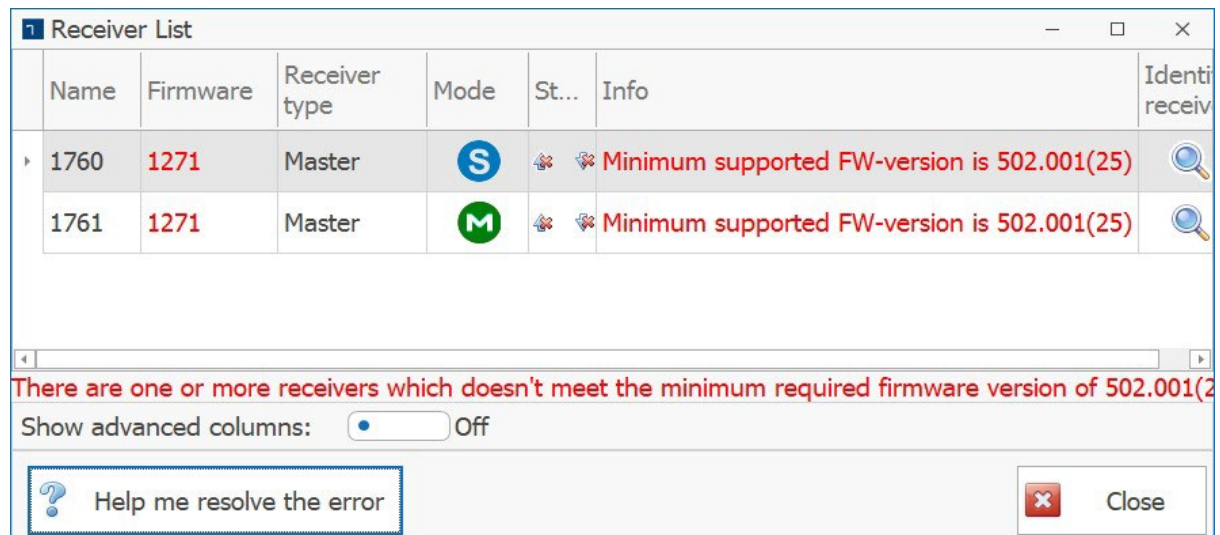

Figure 4 Firmware not supported message

To solve this, click the **Help me resolve the error** button. This opens the Firmware tool, which can also be opened from the application menu. To update the firmware in the receivers, see section 3.1.5. After the firmware has been updated, the receivers are restarted. Connect to them again (allow 30 seconds for system to restart).

Note: If the receivers will be used together with Talon I at some point, the firmware needs to be downgraded to an old version of the firmware (currently, version 1271 is the latest firmware which is supported by Talon I). The downgrade must be done in Talon-2, since Talon I cannot communicate properly with firmware versions aimed for Talon-2. **It is crucial to ensure that the antenna's power remains connected throughout the upgrade/downgrade process.** Disconnecting power during this process may lead to potential issues with the device. **In the worst case, this can lead to a locked antenna, which can only be fixed at the factory in Sweden.**

2 Quick start

1. Set the PC's ethernet interface to static IP:10.10.255.252, netmask:255.255.0.0
2. Ensure that all cables are correctly connected, including Ethernet cable to the PC.
3. Start Talon-2. You are presented with the project options as shown in Figure 5.
4. Power up the Raptor system and wait for about 30 seconds. The antennas will come live and show some flashing LED's.
5. Press **Connect** button from the project options. The button will display connect status **Connecting(x)**, and number of receivers found (x).

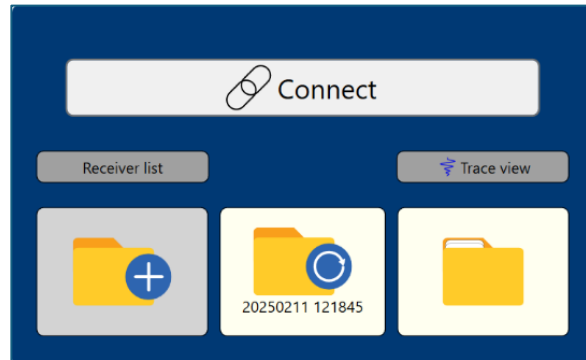

Figure 5 Talon-2 main screen

Connect button will turn **Connected(x)** when a complete array has been detected and verified. Figure 6.

6. Click the New button to create a new project or open an existing project. The project settings are shown, see Figure 6, below, and if you wish to change anything tap the corresponding setting. Confirm settings by tapping the symbol.

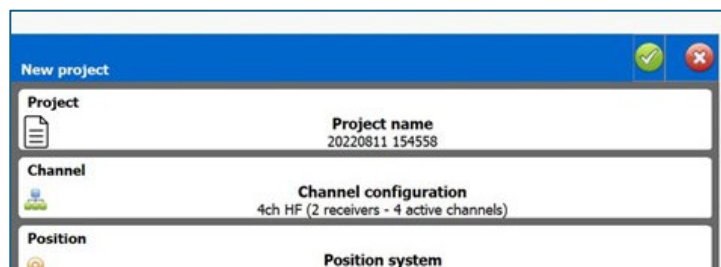

Figure 6 Connecting to Raptor array in Talon-2 and project options

7. After settings have been confirmed for the new project, you are presented with the project overview screen, see Figure 7, from where you can start data acquisition.

8. Hit the Start button (with the green start symbol in the top right corner). Data acquisition will start directly. The Start button will now turn into a stop button.

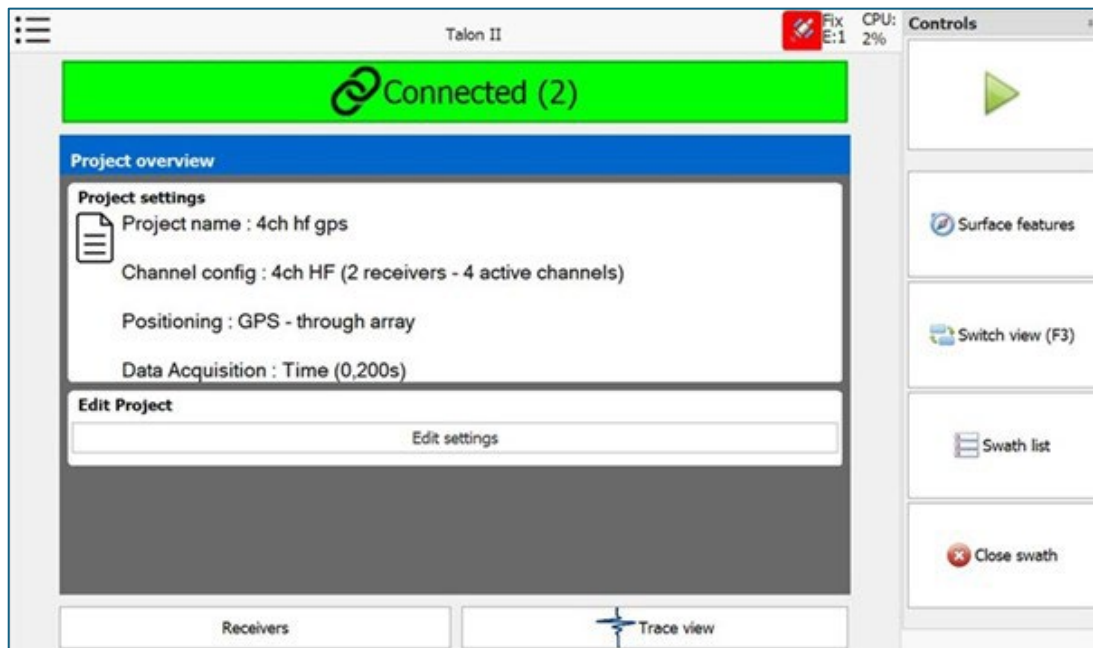

Figure 7 Project start screen

2.1.1 Hints/notes during data collection

Note: The project folder and files are created when the project settings are confirmed in step 7. From going to the project overview, it is still possible to change the project settings until the first swath has been initiated, after which Talon-2 will prevent most alterations. Surface features may be acquired before, during, or after radar data acquisition.

- Positioning indicator will show green if positioning is working and in the accepted range of fix levels (for GPS).
- If a standard laptop is used, stopping/starting data collection is best done by pressing space bar once and then once again for starting the next swath, no dialogues will appear. For touchscreen enabled device, clicking the large start/stop button in the top right corner will do the same thing.
- In radargram view: F4-key let you toggle through the different data channels to check the quality, or by using left and right arrow key. For touchscreen devices. You can simply click the channel to display the radargram.
- In radargram: Time gain and contrast are changed through the contrast indicator symbol.
- Click it to open the level adjustment panel, in which you can change contrast and gain levels. Note that this has not impact on data stored, its always raw.
- If you have internet connection (or saved map on your PC), you may switch between radar data view and map-view with the F3-key (or the switch view button in the acquisition controls to the right on the screen).

- You may start and stop data collection in any of the two acquisition views. The channels are also shown in both the radargram and map view, so the user may always view the state of the controls.
- It's critical to have the positioning data at start- and endpoints of all swaths. Otherwise, Talon-2 has no way of allocating positioning data for those sections, and they will not show up in post processing software's.
- Positioning fallouts are less harmful if profiles are straight, hence we recommend as straight swaths as possible. Also, sharp bends in survey lines will always compress/stretch data to some extent, hence the straighter the better.
- If a swath is obviously corrupt, delete it at once, it's not easy to remember back in office, caution though!
- The better the coverage, the easier interpretation. Minor gaps may be interpolated but remember; that's artificial data.

3 Start screen

When launching Talon-2 the start screen seen in Figure 8 will show up. The indicator panel, top right, as well as the status bar at the bottom will be reserved for their intended purpose throughout the different operations of the software.

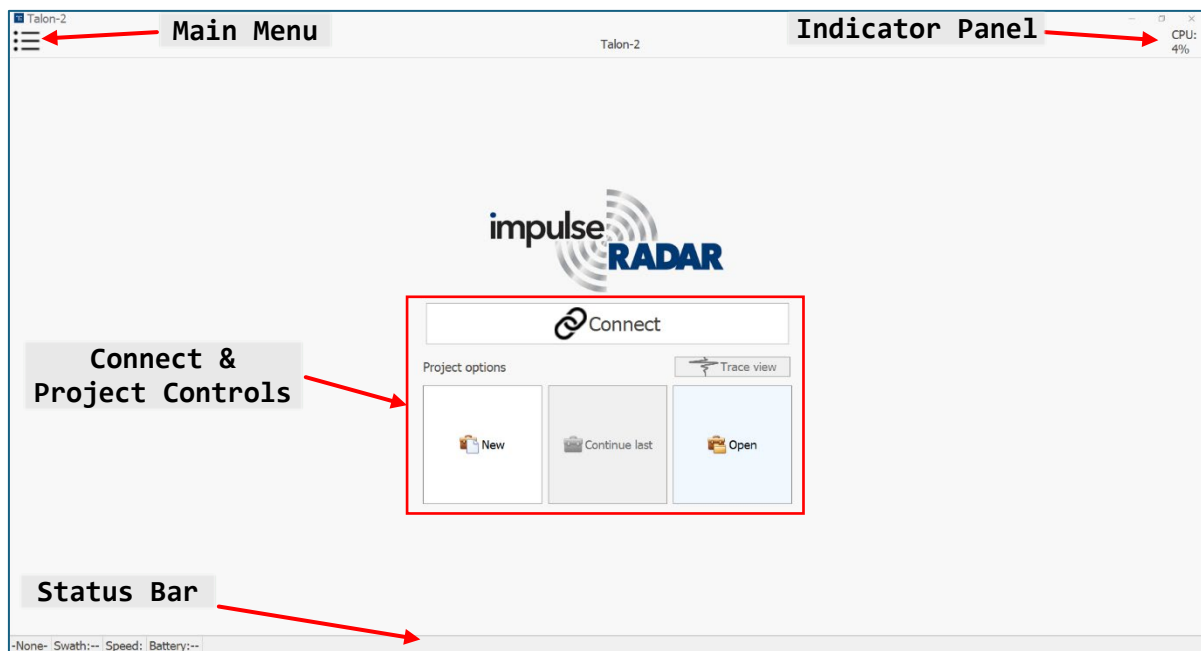

Figure 8 Start screen, Indicator panel and status bar are reserved for their purpose throughout the operations of the software, while the rest of the computer screen change

3.1. Main Application Menu

The main menu, top left, is intended to be used only in controlled environment, i.e., in office. Typically, a user will go directly to the centre controls, connect the array, and start a new project. Following options are available here. Figure 9.

3.1.1 Preferences

In the preferences dialogue the user defines default settings that control how Talon-2 function every time the software is launched. A user may customize the software and thereby the data collection schemes they're frequently using.

Preferences are grouped in four different categories: General, GPS quality levels, Map, Data acquisition and Surface features (also available from other places in the software). Below is a detailed description of each one:

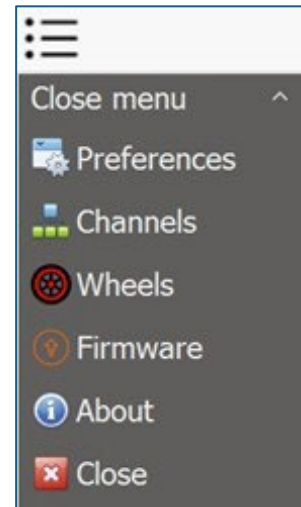

Figure 9 Main application menu & preferences

General

- **Proposed project/file names:** This automatically names a project based on the current date and time.
- **Project root folder:** This is where new projects will be created and opened from as default.
- **Window mode:** Choose either windowed or full-screen mode.
- **Ground velocity:** The ground velocity, which is used for various depth calculations. Default is 10 m/us.
- **Update check interval:** The number of days between checks if a new version of Talon-2 has been released. This is not activated for beta versions of Talon-2.
- **Vertical scale:** Sets if the vertical scale shows depth or two-way travel time (ns).
- **Units:** Metric or imperial.

GPS

- **Quality levels:** If a received GPS position has a fix level which is set as accepted in these settings, the GPS status indicator will turn green, otherwise yellow. Level 4 (RTK) is the recommended setting and the only one that ensures proper survey-grade accuracy. RTK stands for Real-Time Kinematic.

Map

- **Minimum distance between position points:** The minimum distance between received points until they are displayed. This is to limit that small position variations cause plotting.
- **Map provider:** Sets which map provider to use.
- **Map render mode:** Controls how the map view is rendered, i.e., Auto, GdiPlus, DirectX, Direct2D.

Data Acquisition

- **Measure mode:** Choose between Array mode or single receiver.
- **Data format:** 16 or 32-bit data collection. 16-bit is recommended.
- **Allow measure auto-restart:** This allows data acquisition to auto-restart when stopped. Used mainly on road surveys.

- **Default depth for Raptor 17:** The default acquisition depth for Raptor 17 antennas. Note, dependent on ground velocity (see above).
- **Default depth for Raptor 45:** Same for Raptor 45 antennas.
- **Default depth for Raptor 80:** Same for Raptor 80 antennas.
- **Default point distance for Raptor 17:** The default distance between radar data points when using Raptor 17.
- **Default point distance for Raptor 45:** Same for Raptor 45.
- **Default point distance for Raptor 80:** Same for Raptor 80.

3.1.2 Surface feature definitions

Surface features give the operator ability to mark facilities of interest for the project. There's two basic types, points, and lines. For example, a point with known local/global coordinates or a water post. Surface features may help in interpretation and may also illustrate the layout of interpreted features in relation to what's on the surface. Figure 10.

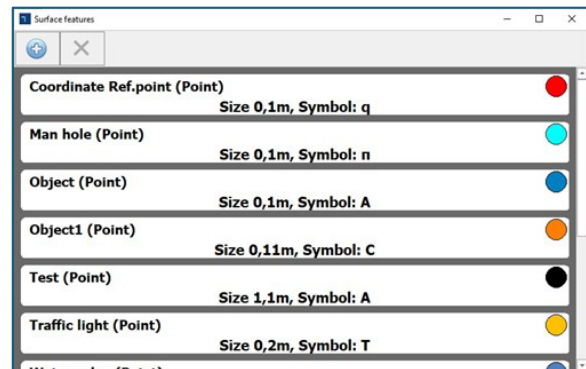

Figure 10 Surface feature definitions

The list presented contains all defined surface features. Each surface feature is shown with the following information:

- **Feature name, the defined feature name:** This will be presented to the user when new surface features are added to the project.
- **Type:** The type of the object, as point or line.
- **Size and symbol:** The size and symbol, which is showing up in the map when the surface feature is created. Only used for point objects
- **Width:** The width of the surface feature. Used for line objects.
- **Color:** The color of the object, as a color marker to the right in each surface feature

Creating a new surface feature definition

Click the Add (+) button at the bottom to add a new surface feature. The new feature will be displayed together with all its properties as shown in Figure 11.

In the New surface feature, its properties can be changed in the same manner as for project settings. Click a setting to change it. Some properties can be changed directly in-place. The fields which can be set are:

Figure 11 New Surface feature dialogue

- **Feature code:** Only changeable for new surface features, not when opening an existing surface feature for modifications.
- **Feature type:** Only changeable for new surface features.
- **Color:** The color of the object
- **Symbol:** The symbol. Only used for point objects
- **Size:** The size of the point object. For line objects, a width property exists

Whenever an object has been created (i.e., the user has closed this form and pressed the feature add '+' sign), the feature name and the type cannot be changed.

Remove a surface feature

To remove a surface feature, click on the surface feature to remove. The clicked feature is displayed (as can be seen in Figure 11, New Surface feature. In the top of the dialog, click the remove button (with the red cross). A confirmation dialog asks if you are sure before deleting the surface feature.

3.1.3 Channels

The Channels submenu lets the user re-define or create new channel configurations. The channel configuration is essential for any postprocessing of array data since it defines each channel position in relation to the GPR/Prism. Figure 12.

	Name: Benrths test1 (8 rec, 16 ch) Type: Raptor 45 Info: Pos.pole height:1,30m		
	Name: Raptor 45 12 p (6 rec, 12 ch) Type: Raptor 45 Info: Pos.pole height:0,00m		
	Name: Raptor 45 12ch perpendicular (6 rec, 12 ch) Type: Raptor 45 Info: Pos.pole height:0,00m		

Buttons: Create new Create custom

Figure 12 The channels submenu let you view, create, or modify channel Configurations

Channel Spacing and radar coverage – Concepts

As shown in Figure 13:

- Whatever the antenna orientation is, we define the position of a channel as the midpoint of a line drawn from centre of the receiver to centre of the transmitter antenna, marked as a star in the figure.
- Channels spacing/separation is the distance between two adjacent channel positions.
- The effective scan width the radar array cover is number of channel times the channel spacing.

Channel position is the critical parameter, the others are more of informative character. The Radar array coverage is used for showing coverage of the survey area during data acquisition, and the physical width of the array is purely informative.

To help users define correct channel configuration Talon-2 has a menu which automatically calculates each channel position based on channel separation and number of receivers as shown in Figure 14.

Note that this tool only works for our standard configurations and for user-defined special configurations, the Rx-Tx distance must be manually input.

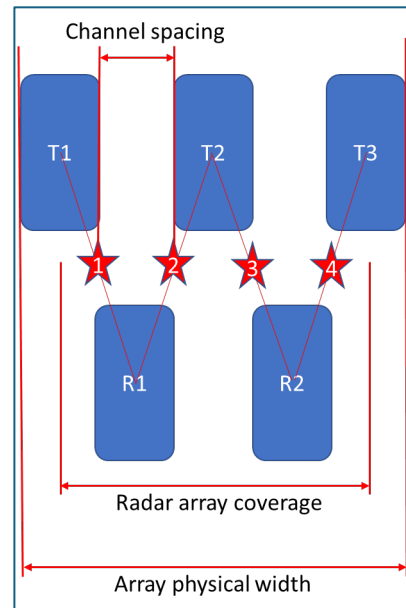

Figure 13 Definition of channel spacing and radar array coverage



Figure 14 Channel configuration menu

Following controls are available for setting a channel configuration:

- **Channel name:** A user supplied name for the channel configuration
- **Array polarization:** How the antennas are oriented; either *In-line* or *Parallel*, used to automatically calculate the width of the array.
- **Receiver count:** The number of receivers in the array. This will be pre-filled with the number of detected receivers when a new configuration is created, if the array is connected.
- **Prism position:** This sets where the prism/GPS is positioned in relation to the center of the array. The array center is marked with a blue cross, and the prism position is marked with a circle with a center dot.
- **Activate/De-active channel:** In this control, separate channels can be activated/deactivated by checking/unchecking each channel.
- **Array radar width:** The scan width that the array will cover, from a radar perspective.
- **Rx-Tx distance:** The distance between a receiver and its transmitter, manual input.
- **Position pole height:** The GPS/prism height above ground. This parameter is important if you want to export interpretation features with absolute height from the interpretation software.

3.1.4 Wheels

We want the radar data to be uniformly positioned over the surveyed area and thus to collect radar data on equidistant points along the survey lines. To achieve this, we mount an odometer to one of the wheels of the vehicle pulling the array or to one of wheels of the cart and connect this odometer output to the master receiver antenna. The master receiver is then controlling the data collection of the whole array to take place on defined points along the

survey lines. Now, the odometer only records tics, and the master receiver, or Talon-2, would know nothing about distances nor what direction is forward/backwards if we did not calibrate this measuring system.

Wheels-functionality in Talon-2 allows you to create new, calibrate and modify existing wheels used for controlling the data acquisition.

When the wheel option is selected, a list of defined wheels is displayed as shown in Figure 15. Here you can create new wheels or modify existing ones. The wheels list does not select which wheel to use in a project, it just allows management of the wheels.

The list will show all existing wheels stored on the computer.

Note: If a GPS system is used together with internal GPS for time-synchronization, an odometer/wheel is not necessary, if there's good GPS coverage (RTK-Fix) over the whole survey area. In those cases, data collection may be based on time-triggering instead. Our support and interpretation software will take care of the data positioning. We have seen no visible deterioration of data quality with this approach. If a total station is used for positioning or if the survey is manually positioned, an odometer/wheel is a must, though.

Modify an existing wheel

To modify an existing wheel, click the settings icon to the right of the configuration to modify. The wheel settings appear, and the wheel name and its calibration can be altered. Figure 16.

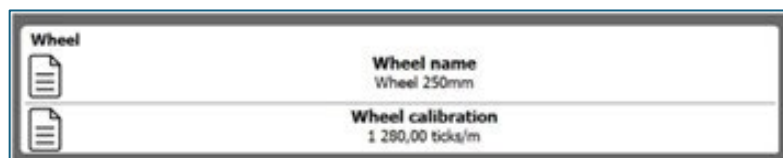



Figure 16 Modify an existing wheel

	Name: Wheel 250mm Info: 1 280,00 ticks/m		
	Name: Test wheel Info: 309,91 ticks/m		
	Name: Tw Info: 1 205,00 ticks/m		
	Name: Test1 1000 fw Info: 1 252,50 ticks/m		
	Name: Test 1000 bk Info: 1 258,00 ticks/m		
	Name: Wheel Info: 309,42 ticks/m		

Figure 15 Wheel configurations

Create a new wheel

Create a new wheel by clicking  the  at the bottom. The wheel settings as shown in Figure 16 will appear.

Calibrate a wheel

An uncalibrated wheel cannot be used for data acquisition, and a calibration which is incorrect may or may not be critical, dependent on the amount of error and positioning system used. GPS is in general the least sensitive, in this case.

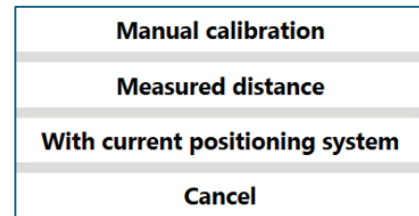

Figure 17 Wheel calibration options

To calibrate the wheel, perform the steps described in the dialog box. When calibration is done with the help of a measured distance, the distance used must be entered manually. When the current positioning system is used, the distance is retrieved automatically.

To calibrate a wheel, open the wheel settings and click the Wheel calibration settings as shown in Figure 17.

It has three options:

- Manual calibration
- Measured distance
- With current positioning system

Note: A minus sign before the distance covered or the tics/m field, indicate reversed direction.

WHEEL CALIBRATION OPTIONS

- **Manual calibration:** It allows the user to directly assign a calibration value (i.e., number of ticks the odometer gives for each travelled unit of distance). Figure 18.

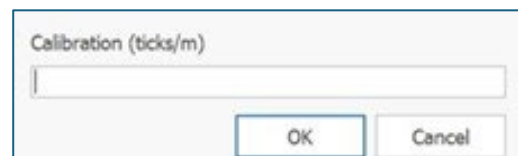
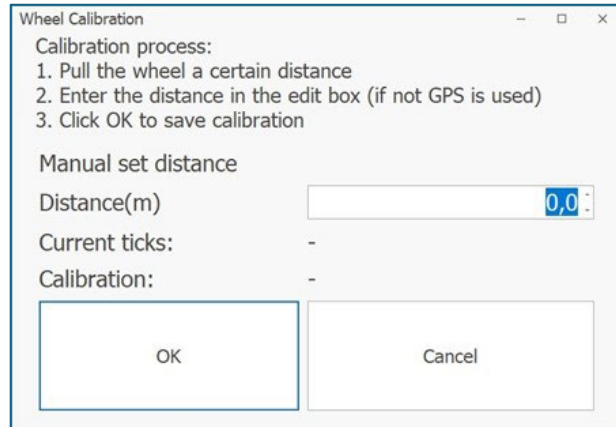

Figure 18 Manual wheel calibration

- **Measured distance:** Shows the calibration dialog where the wheel is calibrated on a known distance, which is entered by the user. This requires that an array be connected, since the wheel data is sent from the master receiver which has the wheel connected. Figure 19.



- **With current positioning system:** *Figure 19 Wheel calibration using measured distance*

Shows the wheel calibration dialog, where the calibration distance is gathered from the current positioning system (RTK-Fix highly recommended). This requires that positioning data can be received, either through a connected array, or that the positioning system is connected directly to the computer. Figure 20.

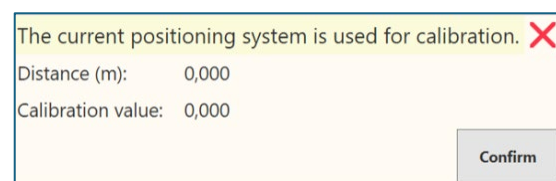

Figure 20 Using current positioning system for the wheel calibration

3.1.5 Firmware

The system firmware resides in the receivers and is upgraded from Talon-2. Specific instructions will accompany such upgrades. During upgrades, or downgrades, it is very important that the system is powered up and connected in a stable way. Loss of power during the upgrade process may render the system non-functional. Similarly, Talon-2 will not allow firmware upgrade if battery levels are too low. Figure 21.

For Talon-2 to be able to communicate with connected receivers, a minimum requirement exists on firmware version. If this is not fulfilled, the receiver list will show up with a message stating that the firmware version is not at the minimum required level.

To upgrade firmware, perform these steps:

- Click the **Select file** button to select the file containing the version to install.
- When the file has been selected, click the **Upgrade** button.
- The upgrade will begin. When it has completed, a message will show stating that the update has been completed.

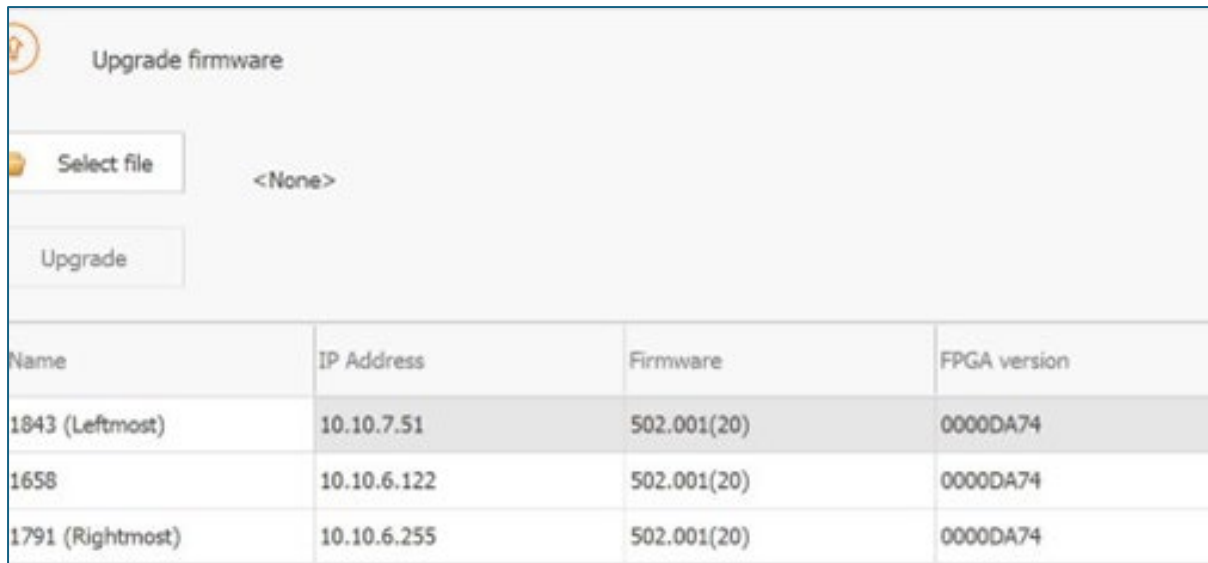

Figure 21 Talon-2 firmware upgrade dialog box

The firmware is upgraded on all connected receivers. For the firmware upgrade process to be performed, there must be at least one receiver connected, and a valid file selected. The file will be verified upon upgrade, so an upgrade will not be possible if the file doesn't contain a valid firmware image.



Firmware versions starting from 502.xxxxx are firmware compatible with Talon-2.

Note: Do not power off your system during a firmware upgrade process. Wait until the message box stating that the upgrade process has finished. A power interruption during the upgrade procedure will result into a hardware failure which can only be fixed in the factory in Sweden.

3.1.6 Indicator panel

The indicator panel shows various indicators/controls depending on where in the software/acquisition process the actions take place. These indicators also have a troubleshooting purpose. The indicators are shown in table below.

	<p>Positioning status</p>	<p>Status for the positioning system. A red colour indicates an error, while yellow a warning. The symbol looks different based on the positioning system used (GPS, Total station, or NONE). To troubleshoot why the positioning system isn't ok, click the status indicator. See section 3.4.3 for positioning system troubleshooting. When GPS is selected as the positioning system, it will also show the fix level (quality level) of the GPS</p>
	<p>Gain/contrast adjustment for 2D-radargrams</p>	<p>This is visible when the radargram is displayed. This is not a real indicator but instead will open a control to allow the user to set contrast and time gain in the radargram.</p>

	Direction indicator	This shows in which direction the cart is moving. If this displays a down array, it means the cart is moving backwards. If the cart is moving forward, but this displays a backward direction, it means that the wheel calibration has been done in the opposite direction. Go to Acquisition settings and change the measure direction to get the direction correct.
	System load	This indicates the system load (i.e., how close it is until there is a risk that traces will be lost). When this is green, all is ok. It will turn Yellow when the system load is close to its limit for reliable data collection. When it is yellow, slow down to ensure data quality.
	CPU load	The CPU utilization

3.1.7 Creating a New Project

Upon start of the application, you are presented with Project options as shown in Figure 22.

The possible options are:

- Connect to an array
- View traces, channel by channel, if an array is connected
- Create a new project
- Continue the last used project
- Open an already existing project

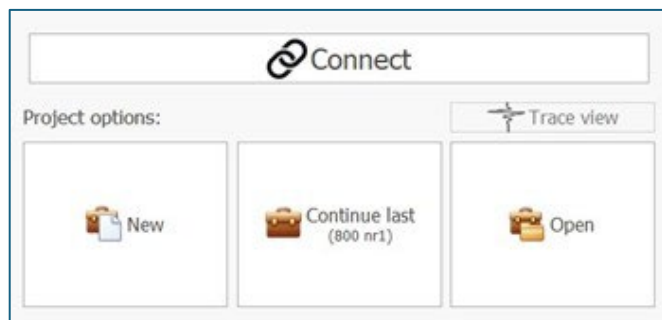

Figure 22 Project options

By starting a new project will take you to the new project dialogue as shown in Figure 27 and after confirming the settings you will end up in the project acquisition window as shown in Figure 28. The difference between new project and continuing an existing project is that for an existing project, most parameters cannot be changed. To clearly distinguish between the two, we've made the entrance to data acquisition window slightly different as shown in Figure 22.

3.1.8 Connecting the array

During the connection process, Talon-2 establishes communication with all receivers in the array and, when successful, will know how many receivers and what type, are hooked up.

Further Talon-2 will check the connection between receivers and read the position of each one within the array.

Once the connect button is pressed, it will indicate progress with color according to table below.

Grey	No connection exists
Green	One or more receivers are connected, without issues
Yellow	Connection in progress
Red	Issues with connected receivers

It will turn yellow during scanning of receivers, with a small text saying that “click to abort”. As soon as a set of valid receivers are detected, it will stop scanning. Valid receivers are:

- **In array mode:** when a valid array has been detected, i.e., at least two receivers connected to each other and with end connectors in place.
- **In single receiver mode:** when one receiver has been detected.

If no set of valid receivers are detected, the scan will retry to search for receivers. To abort a current scan, click the button again. If there are any detected receivers when the scan stops, the button will turn red due to that the detected receivers are not a valid set of receivers. It will turn grey if no receivers are detected during the scan.

During and after a scan, the button will display the current number of detected receivers.

When a valid set of receivers have been detected, it will become green. If a receiver becomes disconnected, the color will turn red.

Once Talon-2 has established communication with an array, it will allow the user to view data from each receiver and to adjust the time-zero of data from each receiver. Note that time-zeros can only be set on a per receiver basis. Also, when connected, Talon-2 will preselect channel configurations based on the type of receivers it has found.

1.1. Trace view

The trace view serves the purpose of checking the radar data on each channel and, if necessary, adjust the position of the first arrival of each pair of channels so that it is located at an acceptable position along the collected signal. If the array was not altered since last survey, no changes should be necessary.

It's good practice to enter this view for verifying proper functionality prior to starting a project or whenever something has been done to the array, for example when switching between 8 and 18 channel configuration or when replacing antennas or cables. Also, it's a good idea to have the array somewhat in the air since conductive soil may squeeze the signal enough to make it look erroneous.

If changes are made, its good practice to set the first arrival so that a flat line is seen for about 30-45 samples before it appears. Setting the first arrival too high may not leave enough space for the time zero to be set and setting it too low is a waste of disk space and system performance.

There's no need, nor possible, to tune the first arrival of all channels to be on the same positions along the trace. This adjustment is done in our post processing software.

The trace view can be seen in Figure 23.

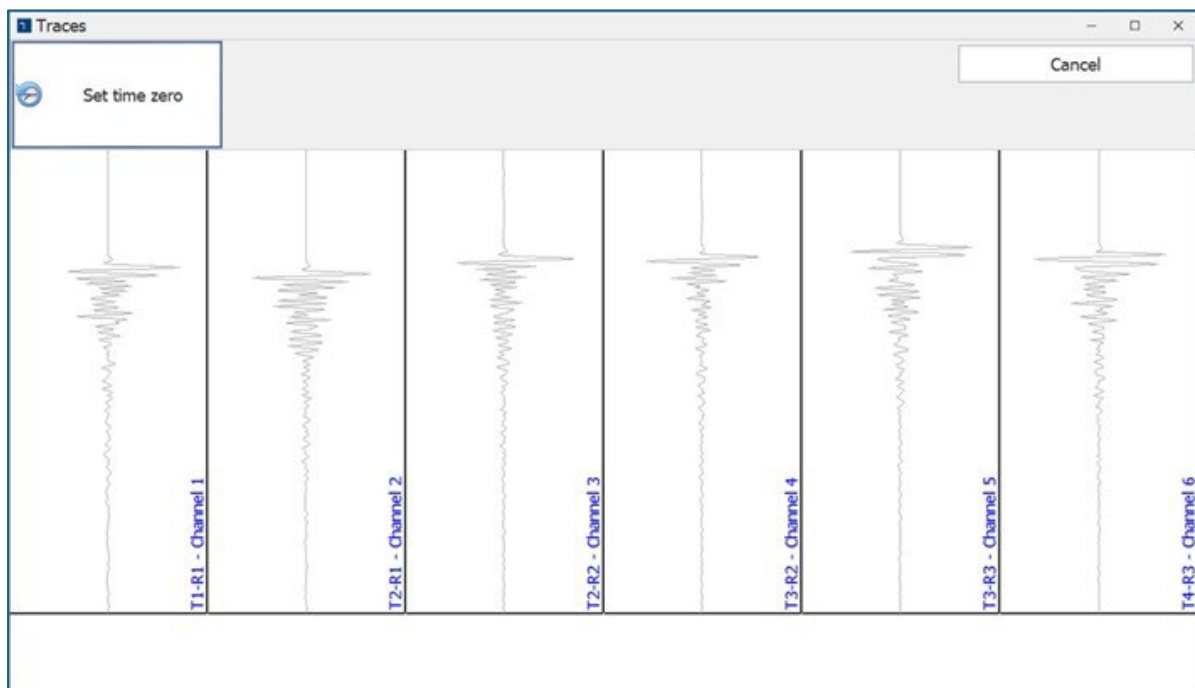

Figure 23 Trace view

In the default view all channels can be seen. If all channels do not fit onto the screen, the channels can be scrolled left or right.

Modify the first arrival manually

To auto set the first arrival for all channels, click the **Set time zero** button. This will auto set the first arrivals on all channels as shown in Figure 24.



Figure 24 First arrival modification controls

These controls allow the first arrival to be changed, either for a single receiver, or for all receivers at once. When a single receiver is selected it will have its channels with a green background.

Referring to Figure 24 and Figure 25. First, select the channel to modify, or click **set time zero** to auto adjust all channels. Note that change on one channel affect the other channel on the same receiver.

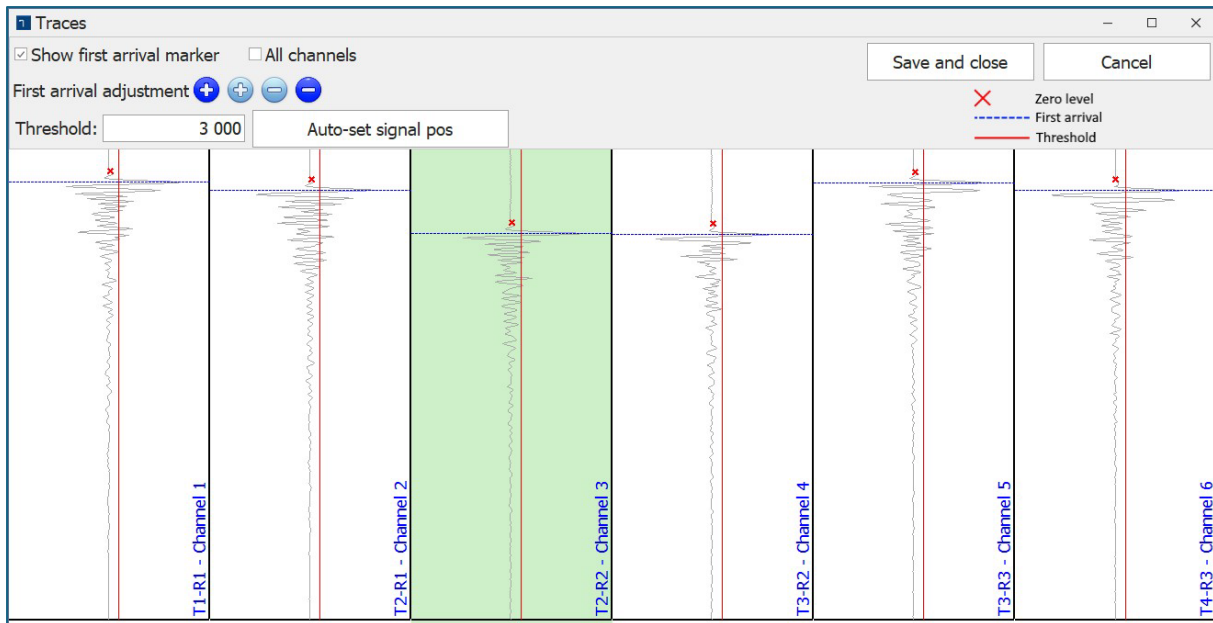

Figure 25 Adjustment of signal positions

The dark blue buttons will modify the first arrival in large steps, while the light blue buttons will affect the first arrival position in smaller steps. The modification will be visible at once in the affected channels.

Modify the first arrival automatically

Referring to figures Figure 23, Figure 24 and Figure 25. First specify the threshold and then tap the *Auto-set signal pos* button. To assist the user, each channel view can show a threshold marker, a first-arrival marker, and the time zero position as blue and red lines. Default value for the threshold is 3000 @ 16bit data and it usually works well, especially if the array is a few cm from the ground surface.

The red vertical line is the threshold (Figure 26). The position at which the incoming signal reaches the threshold level is used to determine the first arrival (the dotted blue line). From the first arrival, the time zero is calculated (the red cross). Time zero is purely informational in Talon-2, we show it to make the operator aware of that it will be modified upwards in the post processing software.

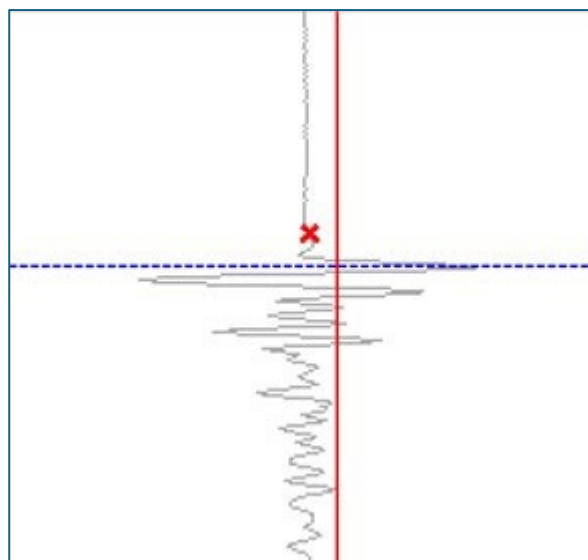

Figure 26 First arrival modification, thresholding

When the signal is auto adjusted, the time zero will be set at a certain sample at around sample 32 in the incoming data. The auto-adjustment is done based on incoming data from the first channel from each receiver, but the second channel will be affected as well.

Save or dismiss first arrival adjustments

To save any modifications done, click the *Save* button at the top of the trace view. This will save the current settings in the receivers. To dismiss the first arrival settings, click the *Cancel* button.

Note! Clicking the cancel button will not restore original first arrival settings in the receivers. To go back to how the incoming data looked before being modified in this dialog, a restart of the receivers is required.

3.1.9 New project/Project overview

When initiating a new project, the menu seen in Figure 27 will show up. Once the project settings are accepted, by tapping the green checkmark, the associated folder/files are created, and the project overview will switch to what is seen in Figure 28 below.

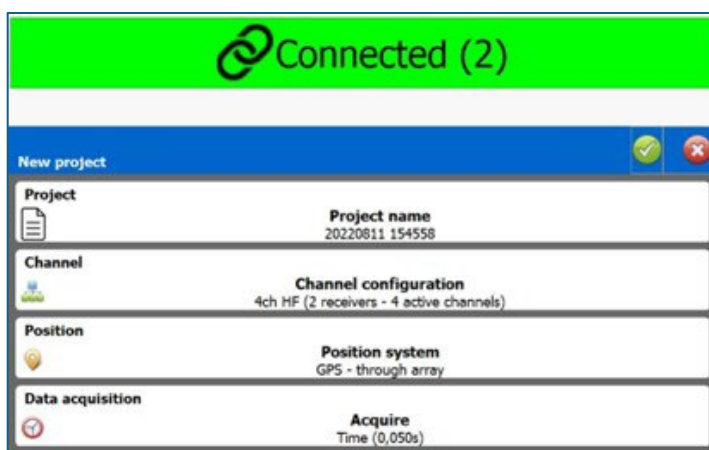

Figure 27 New project menu

The project overview shows the settings for the project. To edit any parameter, hit the button **Edit settings** associated with it, and you'll enter edit mode.

The project settings show the current properties for the project. If any property has a padlock symbol, that property cannot be changed. When continuing an existing project, most parameters will be locked. Project settings include:

- **Project name:** Default name format is **YYYYMMDD HHMMSS**

- **Channel configuration:** This is the number of channels and their position within the array
- **Positioning System:** How the array is positioned. GPS, Total Station, or None
- **Data Acquisition:** How traces will be acquired by the receivers in the array

3.1.10 Changing data acquisition parameters

Project name

All data will be stored under the root-folder specified in the preference settings, see section 3.1.1. However, the folder name and the names of the data files will be derived from the project name associated with the project. To find about the current project settings, go to main menu and then press **Project Settings**. Figure 28.

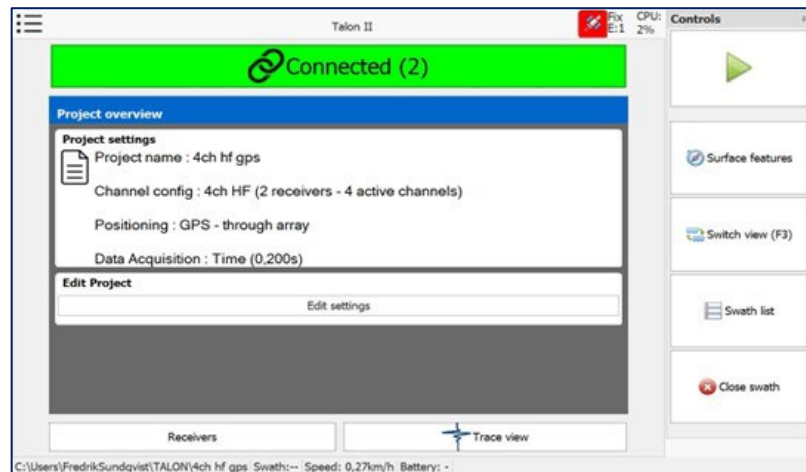

Figure 28 Overview of the currently displayed project.

Channel configuration

Choices of channel configuration is limited to the ones set up in preferences for the specific array connected, in relation to number of receivers and antenna frequencies. More on channel configuration in section 3.1.3.

Positioning system

Here we define what kind of positioning system to use and how data will be transferred to the PC/Talon-2.

Three choices are available as shown in Figure 29.

- **None:** No positioning system is used. With this choice a user is completely on his own, it's not a recommended way, but possible, and in use by some clients.
- **GPS:** A GPS may be connected, either to the master receiver, or directly to the PC
- **Total station:** The data stream from the total station must be linked directly to the PC.

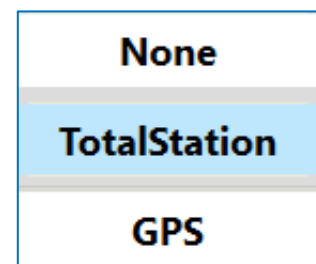

Figure 29 Positioning system options

None/Manual positioning

Swaths can be collected parallel to each other using marked lines on the ground, alternative alignment methods, or an odometer wheel, allowing them to be combined into projects for post-processing. In this setup, ViewR assumes that swaths are measured in a single direction and aligned closely together when generating the .pos files. Although swaths may vary in length, it is crucial to start all swaths from the same reference line to ensure correct positioning. Additionally, Condor software allows for fine adjustments to swath positions.

Figure 30 illustrates Raptor data acquisition with manual positioning. The user starts from a reference point with pre-set X and Y values and then acquires each subsequent swath to the right of the previous one. Since the Raptor pushcart has a coverage width of 59 cm, the user moves 59 cm to the right for each new swath. However, if greater separation between swaths is desired, that is possible, and the separation distance can be specified in ViewR to correctly georeferenced the swaths.

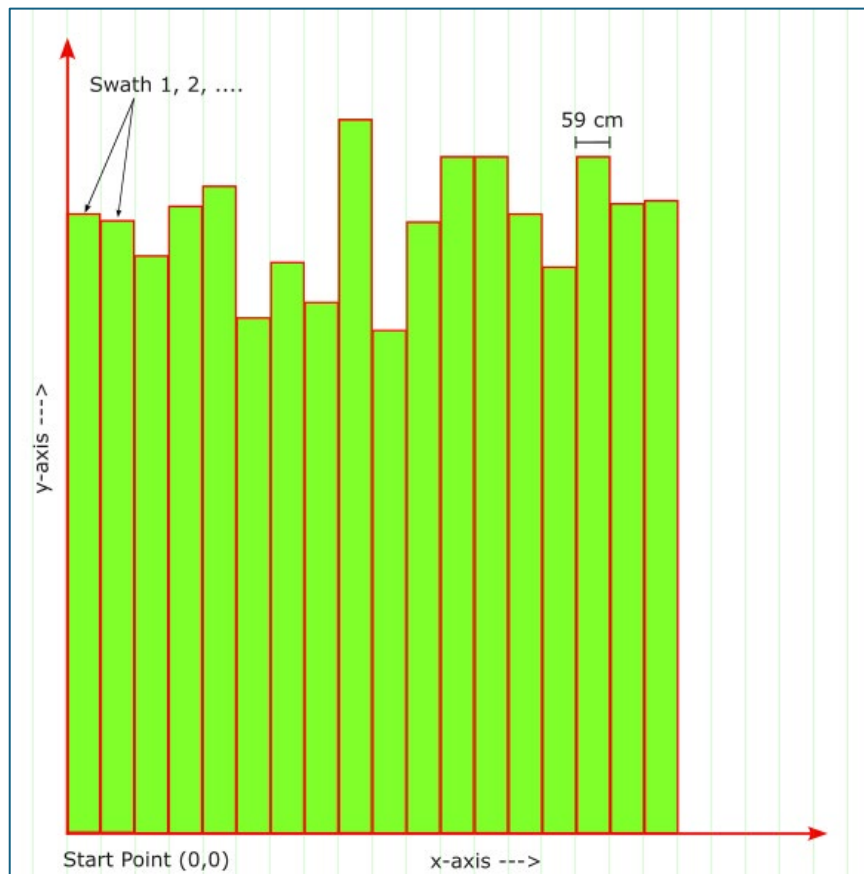

Figure 30 Raptor data acquisition using manual positioning

GPS

In the properties for the GPS, the connection method and incoming serial data is displayed. Clicking on the **Connection type** displays settings for how it is connected in detail:

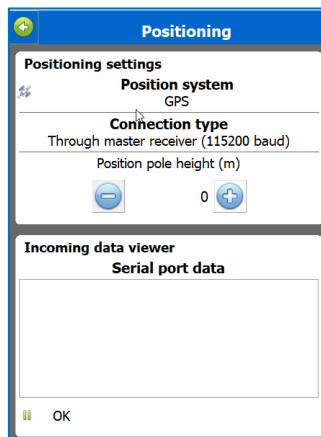

Figure 32 GPS connection through master receiver

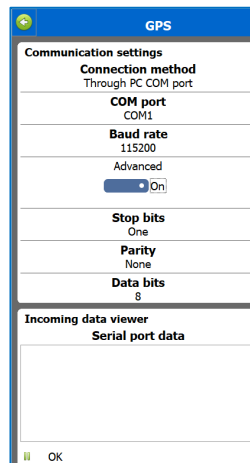

Figure 31 GPS connection through PC COM port

In these settings, it can be set:

- How the GPS will be connected
 - Through PC COM port. Figure 31.
 - Through master receiver. Figure 32.
- **Baud rate:** Talon-2 accepts a maximum of 115200.
- **More settings for COM Port:** These shows settings to be able to control the COM port settings when connected through the PC COM port. When connecting through the master receiver, only the baud rate is changeable.

The parameter 'Position pole height' will be subtracted from the height reported by the positioning system, when the data is combined for processing in Condor.

When correct parameters have been set, incoming data will be displayed in the field at the end of the dialog box. If the serial data viewer list is empty, try other settings for the COM port, don't proceed without ensuring positing data.

Total station

Total stations must be connected directly to the PC. User needs to select total station as positioning source as shown in Figure 33.

Reference points (also named tie-in points) should be defined prior to radar data collection if the total station will be moved during the project.

For each TS position, there must be at least two tie-in points with line of sight to the next TS position. This will ensure that all acquired data from all TS-positions can be referenced within the same coordinate system.

It is also a good practice to establish reference-points prior to data acquisition, since if the TS is accidentally moved during the survey, it can be re-positioned, and the survey continued without troubles. Without reference points, each TS position will render a separate project.

Note that, from the radar perspective it's not necessary to establish the Total Station in a coordinate system prior to a survey. That may be done afterwards, with the help of surface features placed at known positions, which can be measured in after the survey.

The process to establish tie-in points is straightforward. After hitting the *Set total station* button, Figure 34, the menu shown in Figure 35 will show up.

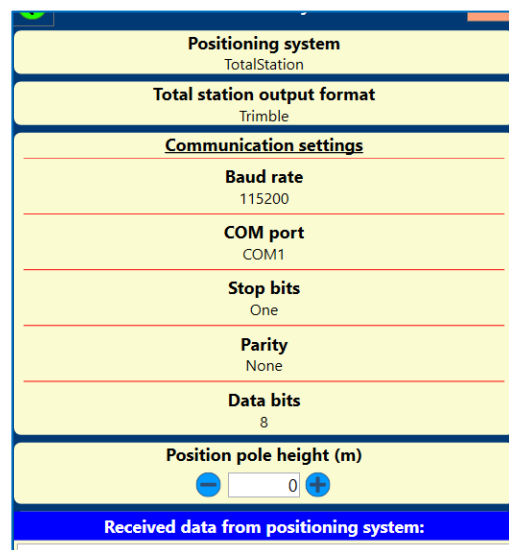

Figure 33 Total station communication settings

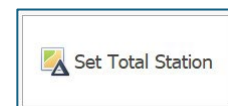

Figure 34 Button for defining tie-in points

1. In the reference point ID column, assign a tie-in point ID. This ID will uniquely identify the point. Two tie-in points for a total station setup must exist in a previous setup. For the first setup, use any ID.
2. Click the Acquire button at the end of the row. The current position from the total station will be fetched.
3. Repeat step 1 and 2 for the second reference point. Give it another ID. repeat for all tie-in points to use.
4. If this is not the first setup, two of the ID values specified must exist in a previous total station setup. Keep track on the ID values used since they cannot be retrieved.
5. When all reference points have been specified, click *Save and Exit*. Data acquisition can now start.

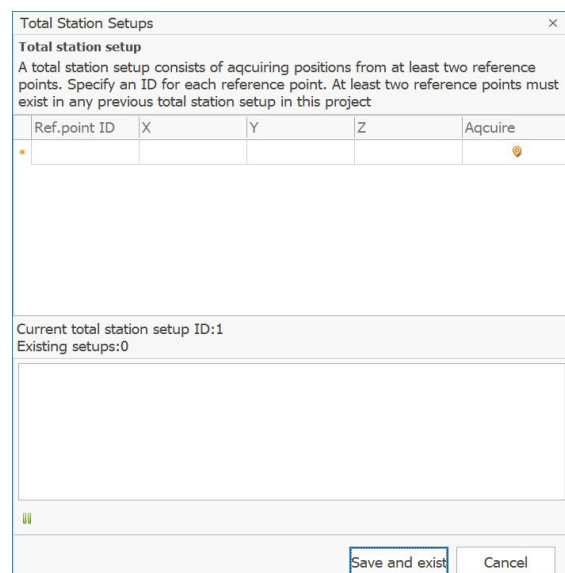

Figure 35 Menu for defining tie-in points

Radar Data Acquisition Parameters

Here we specify how the radar data is to be gathered. Figure 36.

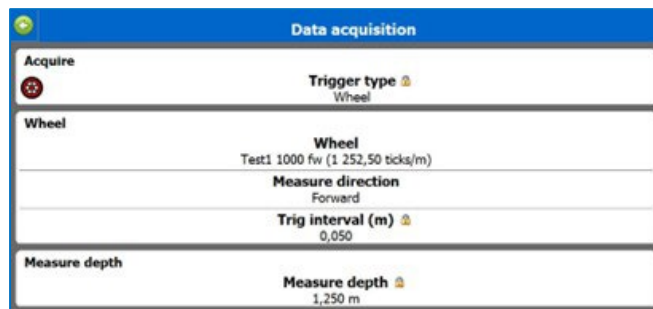

Figure 36 Data acquisition settings

- **Trigger type:** Either time or wheel. Based on this setting, the remaining settings will change to reflect the choice.
- **Wheel:** This opens settings to allow the user to select which wheel to use in the project. New wheels, or calibration of existing wheels is done through the applications menu.
- **Measure direction:** The direction in which the array will gather data. Normally this is forward, but a user may need to alter the direction.
- **Trig interval:** How often traces shall be gathered. When trigger type is set to time, this will be the number of traces per second.
- **Measure depth:** Time-window/Depth is the two-way travel time, defining how deep the recorded radar signal will reach (which is usually defined by geology). Note that the depth is calculated based on the soil velocity defined in preferences.

Surface features

Surface features are surface objects, such as manholes, traffic lights, road edges, positions with known coordinates etc. Surface features contain definition of the feature itself as well as the coordinates of its location. How to define different types of features is described in section 3.1.2. They can be brought into the project, before, during, or after the radar data collection, provided their positions are acquired within the same coordinate system as the radar data.

Creating a new Surface feature

Click the **Surface features** button located on the map, the surface feature control will show at the top part of the map as shown in Figure 37.



Figure 37 Creating a surface feature

1. Select the type of surface feature to create. This is done by tapping the type of currently selected surface feature.
2. (The button with the text Traffic light in the Figure 37). A list of defined surface features appears see Figure 38. Select the type to use.
3. Tap the play button to start acquiring positions for the new object. If the surface feature type selected is a ► point object, the object will be completed as soon as the first position arrives. When a line type is selected, positioning collection will continue until the user ■ taps Stop acquire button
4. When a new surface feature has been completed the feature can be renamed or deleted.

5. Click the play button to start acquiring positions for a new surface feature (the same as already selected) or select a new surface feature to place. Repeat above 1-3 steps for every new object.
6. Close the tool by clicking the red close cross in the upper corner **✗**

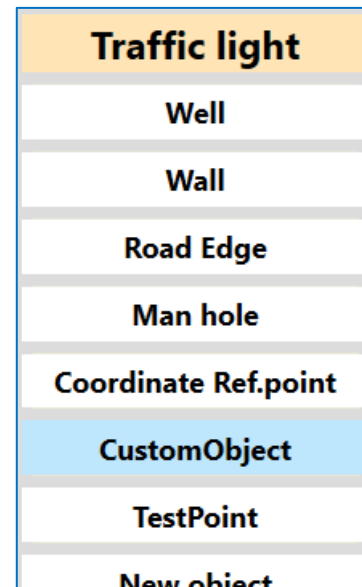

Figure 38 Selection of surface features to be created within the project

Connected receivers

To view which receivers are connected and their properties, a receivers list can be opened from main application window as shown in Figure 39. The functionality described in this section is mainly used during troubleshooting.

The receiver list will show up automatically if any error is detected while Talon-2 is connecting to the array. The error will show in **RED** in the list, for example, if a sync-cable is missing or if no, or if two, masters are assigned.

In the list, shown in Figure 39, the list of receivers is ordered as the left-most receiver first. If a connection between two receivers is broken, it will show up and from that broken connection onwards, the list is not valid.

Name	Firmware	Receiver type	Mode	St...	Identify receiver
1760 (Leftmost)	502.001(22)	Master	M	↓	🔍
1759	502.001(22)	Master	S	↓	🔍
1761 (Rightmost)	502.001(22)	Master	S	↓	🔍

Show advanced columns: Off

Close

Figure 39 List of receivers

The columns in above figure are:

- **Name:** The name of the receiver, derived from the last four digit of their serial numbers.
- **Firmware:** Current firmware of the receiver

- **State:** This shows the connection for the receiver to its left (the UP arrow), and to its right (the DOWN array). If a receiver doesn't have connection to either its left or right, the state will show an arrow with a red cross. This indicates that a connection does not exist. Check cables between the receivers. **Note: If the end sync connector is missing or not detected on the right-most receiver, the left-most receiver will also not be detected.**
- **Mode:** The mode the receiver is set to, Master or Slave and there can be only one Master in an array. Clicking this will set the receiver to master mode, and any other existing master will become a slave. Configuring a non-master receiver as a master in this menu is possible but would only work for manual positioning or positioning with a total station, based on time triggering of data collection, not a recommended way of conducting surveys
- **Receiver type:** The type of receiver. A master receiver type has connectors for wheel, internal and external GPS. A slave receiver types has no wheel or GPS-connectors.
- **Identify receiver:** This will start blinking all LEDs on the clicked receiver (and shut down all other LEDs on other receivers). This is useful if one receiver must be identified. Click it again to stop blinking or close the dialog.

4 Data acquisition

4.1. Project start screen

After the user accepts project setting shown in Figure 27, the project start screen appears as shown in Figure 40. This screen is shown whenever a project is opened, and allows the user to see current project settings by going to Main menu and then clicking Project settings, and to start and control a survey, as well as a few other tasks.

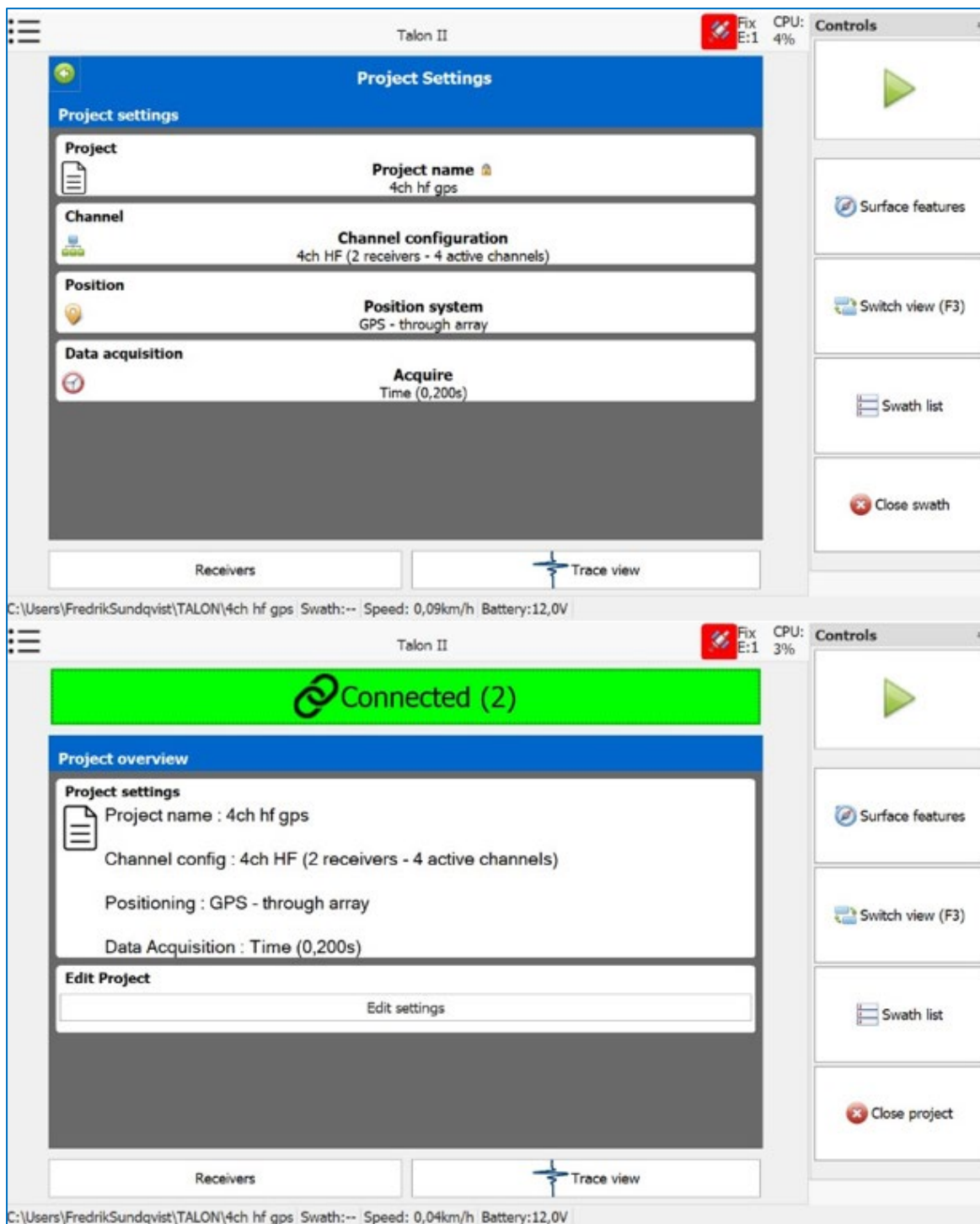

Figure 40 The start screen differs slightly depending on whether it was reached by opening an existing project or from creating a new one. Top shows the screen when creating a new project, data acquisition may start from here.

4.1.1 Keyboard shortcuts during data acquisition

If a keyboard is connected to the computer, keyboard shortcuts can be used for common actions within the application, providing an alternative to the touchscreen or mouse. The available shortcuts are listed in the table below.

Shortcut	Description
Space	Start / stop measure
F2	Connect to receivers
F3	Switch view (map – radargram)
F4	Go to next channel in radargram
F6	Place marker
Left and right arrows	In radargram, go to next/previous channel

4.1.2 Data acquisition controls

Referring to Figure 41:

- Start/stop acquisition. This button change appearance to a stop button once data acquisition is initiated.
- Surface feature. Allows the user to place surface features in the map, such as walls, manholes etc. During data acquisition, this switches to “Place marker” mode, in which the user will place a marker at the current position.
- Switch view. This switch view between the radargram and the map view. When no positioning system is used, the map view is not available.
- Set Total Station. Allows the user to establish the Total station prior to a survey as well as defining tie-in points.
- Auto restart. This is a check button which can be checked / unchecked. In checked state, it will be “pressed” all the time. When checked, a new swath will automatically restart when the previous is stopped. To stop the surveying, this must first be unchecked. **Note!** This button is only visible if **Allow Measure Auto Restart** under **Measure Settings** is set in the preferences.
- Swath list shows a list of existing swaths in the current project. It allows swaths to be opened or deleted. See Swath list in section 4.1.3 for more information on the swath list.
- Close swath / Close Project. In case no swath is active, the project will be closed.

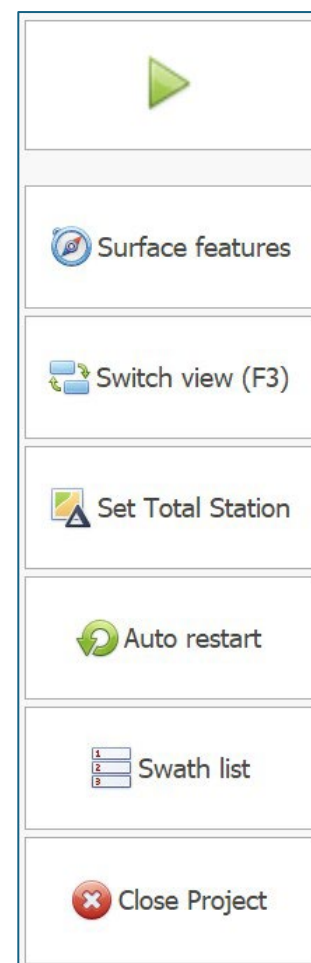

Figure 41 Data acquisition control buttons

4.1.3 Swath list

The swath list is reachable from the footer bar, which is displayed when a project is open. The swath list shows a list of all-existing swaths in the current project as shown in Figure 42.

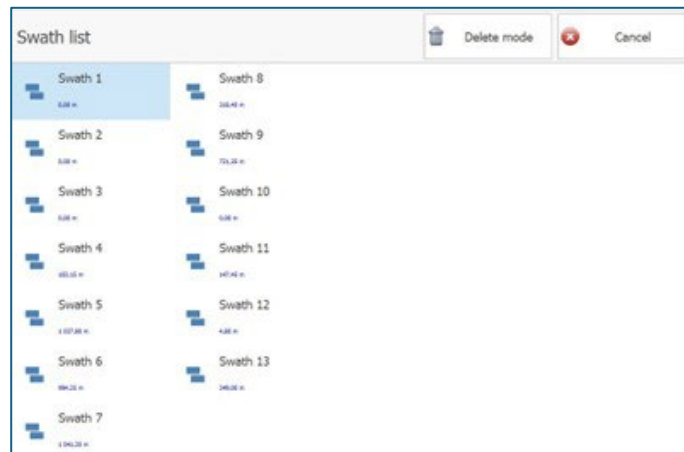

Figure 42 Swath list

Open a swath

Click on the swath in the list. The swath is opened, and the radargram is shown with the opened swath.

Delete swaths

To delete one or more swaths, perform the following:

- Click the **Delete Mode** button at the top. The button turns red to indicate that the list is in delete mode, as well as changes text to Delete
- Select one or more swaths to delete.
- Click the Delete button. A question shows which asks if this is what the user wants. If yes is clicked, selected swaths are deleted, permanently.

4.1.4 Positioning system status window

The positioning status icon will change its symbol based on which positioning system in use. When the status icon is clicked, a window opens (Figure 43) which displays incoming data from the positioning system in use. The background color of the status icon reflects the positioning status.

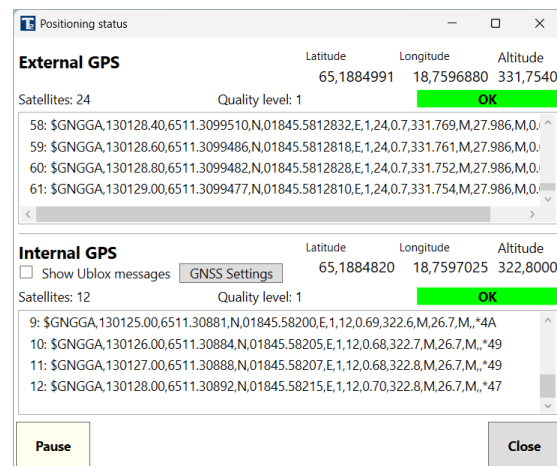

Figure 43 Positioning status window

For GPS system, it looks as:

- **Green:** Positioning system OK
- **Yellow:** Positioning system OK but received data is of less quality than specified (only applies to GPS positioning system). It can also be due to that the GPS system used for time synchronization does not receive a PPS (Pulse Per Second) signal and relies on internal crystals. It is an indication that not everything is fully operational.
- **Red:** Positioning system not OK. Data acquisition cannot start when it is in this mode. The status area displays the reason behind the current state of the positioning system.

4.1.5 Radargram view

The application will start up in radargram view (Figure 44). In this view, indicators for all channels are shown above the radargram. To switch between channels, click on the corresponding channel indicator, or use left- or right-arrow keys.

The x-axis of the radargram represents distance (meters), while the y-axis can display either time or depth, depending on the user's settings in Preferences. The displayed depth is calculated based on the current project velocity. To switch between channels, users can click on the corresponding channel indicator or use the left and right arrow keys.

Use the level adjustment control in the status bar on top of the application to change contrast and time gains.

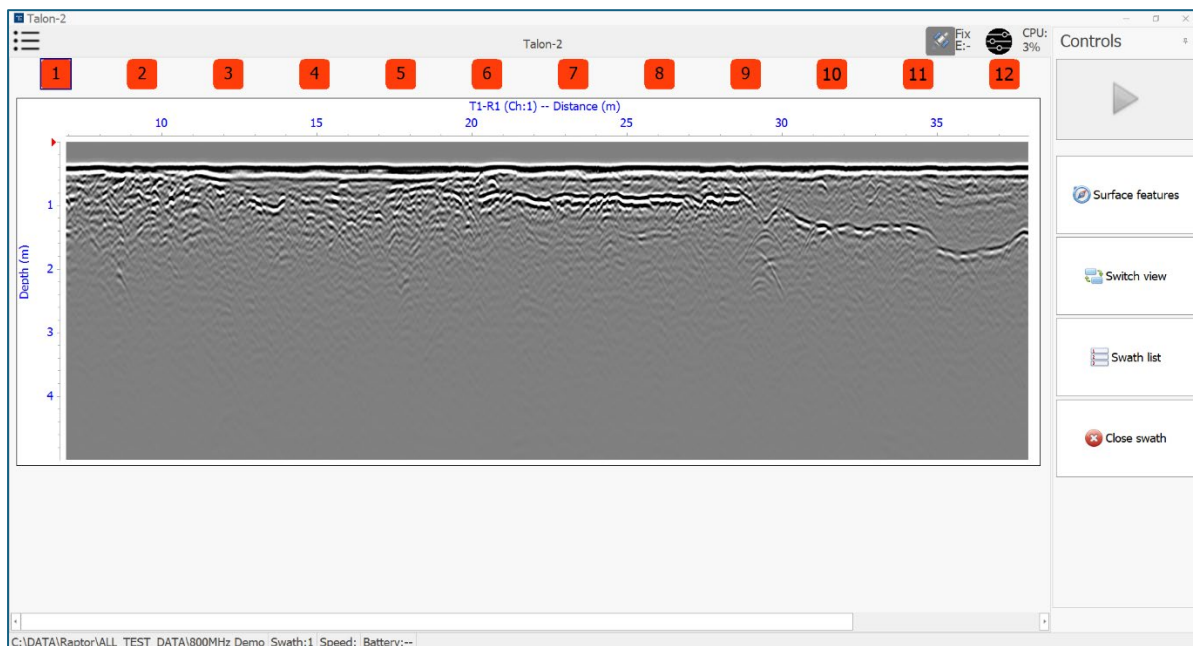

Figure 44 Radargram view

In the same manner as other controls, the channel control color shows the state of each channel:

- **Green:** Ok
- **Yellow:** Warning. There are missed traces.
- **Orange:** Number of missed traces in a swath have exceeded a set limit. Slow down to allow all channels to collect traces.
- **Red:** The receiver for the channel is disconnected. If this happens during data acquisition, it will be stopped.

4.1.6 Map view

The map view shows a map around the current position. Figure 45. Map view is only available when a GPS positioning system has been selected (positioning system = NONE will not allow the map view to display). If a total station is used, the map will be blank, still useful for navigating the swaths.

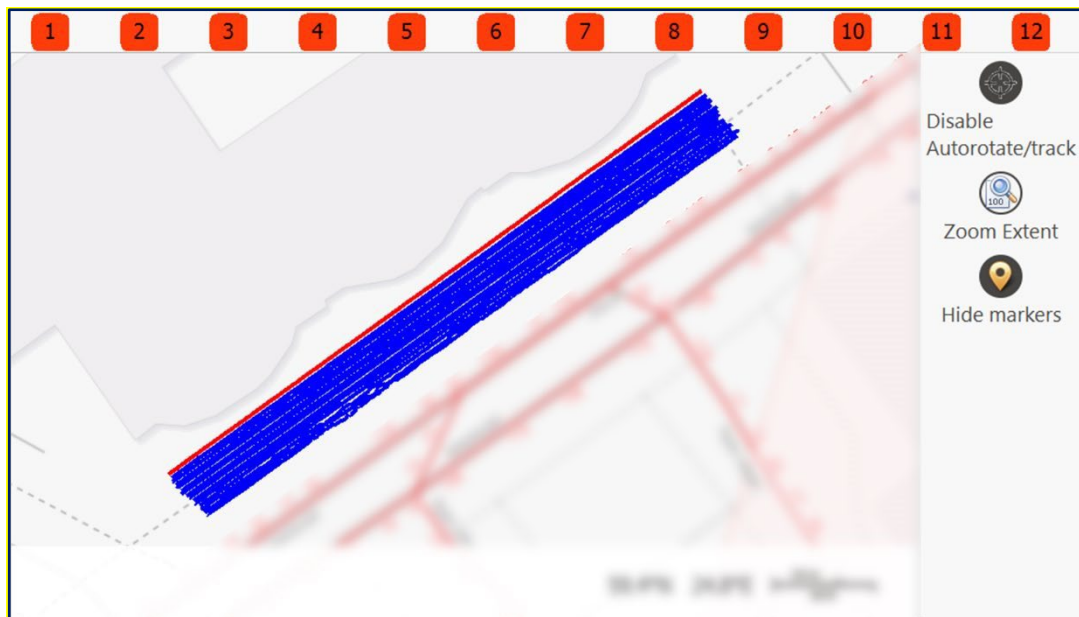

Figure 45 Map view (blurred for source protection)

The map view contains controls to the right of the map, which are:

- Disable Autorotate/track – this disables/enables the autorotate and track. When it is enabled, the map will center on the last received position, and rotate so that travel direction is always up on the screen. You cannot drag the map to show another location when it is enabled – it will always move to the latest received position.
- Zoom extent – This will zoom the map so that all swaths in the project are visible in the map control
- Hide/show Markers – This will hide (or show) all markers, which can be surface features, or markers placed in a swath. When clicked to hide the markers, its text will be *Show markers* to clarify what will happen when the button is clicked

The start button becomes a stop button which is used to stop the ongoing measure. During data acquisition, the data is shown in the radargram. Switch channel to watch another channel by clicking the channel icon above the radargram (the green squares). It is also possible to use arrow keys to switch between channels.

During or after a completed survey, it is possible to look through the collected data for all channels. Whenever the swath is closed, it can be opened again through the Swath list button in the controls to the right.

A measure which is set to have any type of positioning system, cannot start if no positioning data has been received, or that the last received positioning data is too old.

5 Appendix 1: Coordinates for channel set-up

Each channel must have an individual position within the array configuration, in relation to the GPS antenna or Total Station prism. In Figure 46, below we show how our standard configurations are positioned.

All channels have the same Y-positions, while the X varies (in our standard configurations).

When a standard channel configuration is setup, the array-coverage (see figure), and the prism/GPS position in relation to the array center is specified. For custom channel configurations, each antennas position, in relation with the prism position is specified.

Note that it's important that this is correctly assigned in the software.

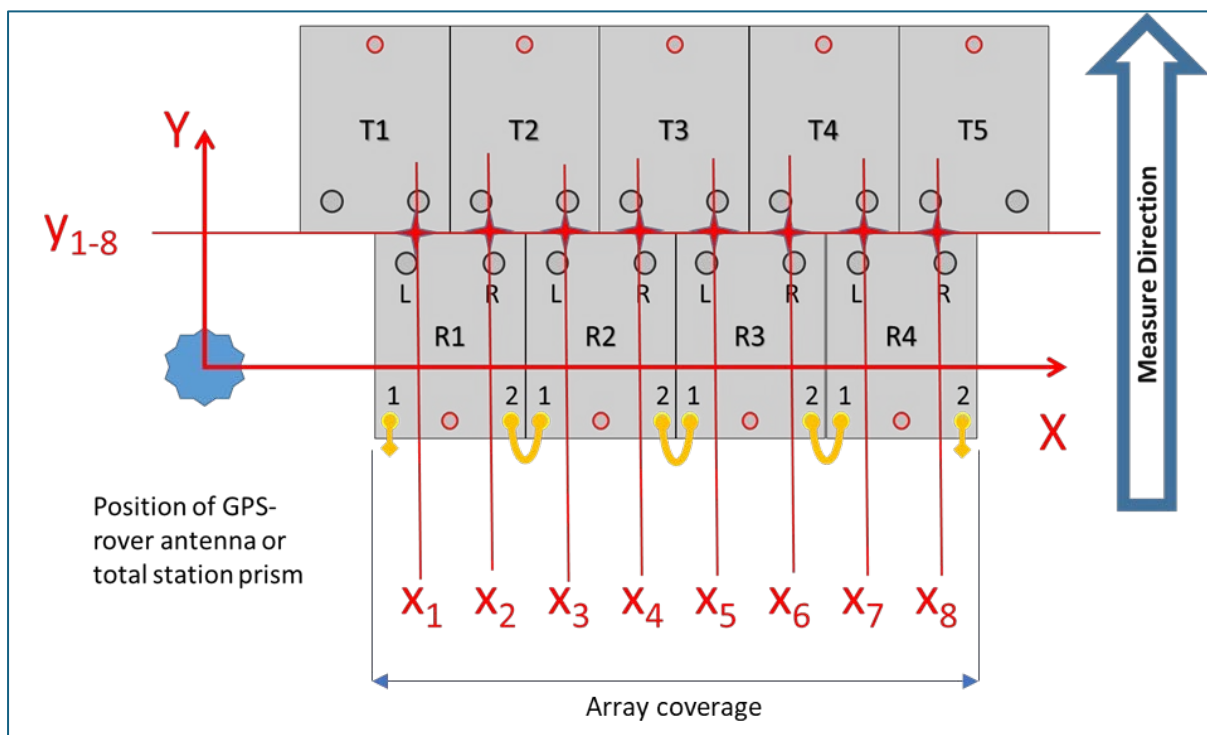
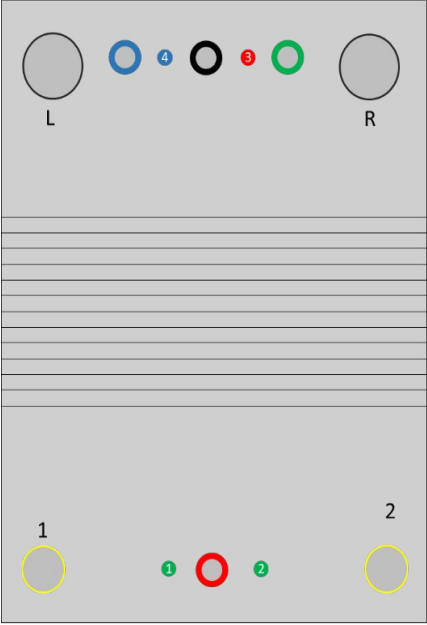

Figure 46 Positioning convention for individual channels

6 Appendix 2: LED-codes

Top view and LED's, Master receiver

	No.	Color	Status Description
	1	Green	Slow Flash: Receiver, slave Constant ON: Not connected to s/w or Measuring Fast flash: Master
	2	Green	Flashes for a few milliseconds on Ethernet activity
	3	Red	OFF: Is OK Flash: ERROR code ON: Not connected to PC
	4	Blue	GPS: OFF or no GPS 1 Flash: Internal GPS 2 Flashes: External GPS ON: Both

7 Appendix 3: Files and file-formats, naming conventions

Files stored in the project directory:

There are several different files for a project, and for each measure swath. This table lists the files and their content for project files.

Note: Not all file types are available for every swath or project. The file types created depend on the project settings.

File extension	Content	Description
.IRP	Project settings	Holds project settings, such as selected wheel and channel configurations for the project, unit system etc.
.IPRH	Header file for a channel	One header file for each channel exists, for each swath. A measure with 8 channels contains 8 header files.
.IPRB	Data file for a channel	The collected data for a channel during a measure
.TIME	GPR times from the internal GPS	Each collected trace number, together with the time when the trace was collected
.ORD	Channel positions	Used to detect presence of a swath
.TSP	Total station positioning data	Corresponds to the .TIME file, but for a total station measure
.GPS	GPS collected data	Collected and interpreted received GPS data from the external GPS.
.OFTPROJ	Surface features	Contains all surface features collected for a project
.MRK	Marker file	Contains which markers have been created during a measure. Markers are positioned on a trace, instead of an absolute position.
.COR	A combine trace and position file.	This file is created after a measure if required, and used during combined files creation, for further processing in Condor application.

8 Appendix 4: Troubleshooting

In this section, common issues and solutions are listed to help you to sort out any problem which could prevent a measure to start for example:

Issue	Solution
<p>Talon-2 is reporting that no Ethernet interface is found with the required address (10.10.255.252), even though this is set.</p>	<p>Talon-2 will only detect correct address if a network cable is attached to that network interface, and that the switch connected in the other end of that cable is powered on and working. Verify that the ethernet cable is connected with the PC and the switch in the Raptor system, and that the switch is powered on</p>
<p>I am moving the cart, but no traces arrive or are not showing in the radargram.</p>	<p>This can be due to calibration direction and assigned measure direction. Verify that the direction indicator (Direction indicator described in page 18) is showing forward when the cart is moved forward. If the indicator is showing backward direction, change the measure direction in Acquire settings</p>
<p>Map view does not show any map.</p>	<p>Select a map provider in the Preferences. You are also required to have an internet connection for the map to download.</p>
<p>The GPS indicator does not turn green, even though the received data is good.</p>	<p>The GPS indicator will turn green if data is incoming from the internal GPS, and that the received positionings from the external GPS has an accepted GPS fix level. The accepted GPS fix levels are configured in preferences.</p> <p>Example: If the accepted GPS fix levels are set to 5, and incoming data contains fix level 4, the status indicator will become yellow.</p> <p>Note: Even if the received GPS is not within the accepted GPS fix levels, the incoming positions will still be collected. The fix level only affects the indicator color.</p>

When issues are detected in an array, the connect button will turn red. Figure 47.



Figure 47 Connect button with errors detected

To further investigate the cause of the issue, open the receiver list, which is opened from the main window.

The receiver list contains information for the cause of the error:

Connection State	Name	Firmware	Receiver Mode	Receiver type	State	Master	Find
NotConnected	1843 (Leftmost)	502.001(20)	Slave	Slave	↑ ↓	↔	🔍
Connected	1658	502.001(20)	Slave	Slave	↑ ↓	↔	🔍
Connected	1791 (Rightmost)	502.001(20)	Master	Master	↑ ↓		🔍

Show advanced columns: Off

✖ Close

Figure 48 Receiver list with detected issue

The receiver list marks the issue with red text. In the above example, Figure 48, there is an issue with the 1843 receiver. We can also see in the Connection state that it is not connected.

9 Appendix 5: Total station set-up

Instruction on how to set up a Trimble S7 and field computer TSC3 for working with Raptor.

General:

For the radar data to be processed the relative positioning between all data in the project must be on cm-level. The absolute positioning is not critical for the data collection, processing or interpretation steps. So, the total station does not need to be localized correctly for this reason. However, if the total station is not localized and you want to position the interpretations in a local coordinate system you must ensure that the start or end points of at least two swaths (survey lines) are at known locations in that local coordinate system (and precisely so). You may then use the coordinate transformation function in CONDOR to position the interpretations correctly, by using these known coordinates.

Note: the goal is to make the TS spit out x, y, z on the serial port continuously, at 10Hz. This is done by activating user configured data output with GDM-labels. The trickiest thing in this is to get past the TS-establishment procedure, once you have this done once, you may use the same for all consecutive projects, since you may move the whole project from within the Condor processing software.

1. Turn on S7 and the field computer and attach TSC3 with a com cable to the data collection PC.
2. Press the General survey icon on TSC3, if there is only one S7 nearby it will be connected immediately. Turn on the prism and direct the S7 towards it.
3. Wait until the TSC3 shows a total station-symbol in the top-right corner.
4. See to that TRK and Auto-lock is activated (The letter 'T' is shown besides the instrument symbol and that a solid line is connecting the instrument with the 'T'). If not, press on the TS symbol and adjust settings.
5. Press the level-tube-icon and adjust the levelling of the S7. If needed.
6. Press the Job-icon and select new job or choose one from the list.
7. If you do not have a TS-establishment, go to the measurement menu, and do as follows:
 - a) If you earlier did a TS establishment-> select "Use Latest"
 - b) If you have not established this TS earlier-> Choose VX and S-series.
 - i) Choose station establishment
 - ii) Adjust and accept the level-values
 - iii) Put in values for pressure and temperature, pressure can be read directly from the instrument and the temp is not super-critical. Accept the values
 - iv) Give a station-point name. This is the name for the position of the S7
 - v) Choose or create a point-code, this is arbitrary. Press <Enter> to accept.
 - vi) Tap in the instrument height. This is the height from ground to the S7's lens, press <Enter> to accept
 - vii) Tap in values for coordinates for the S7. These values cannot be zero. You may for example use 1000, 1000, 0 so that coordinates during the survey do not go below zero (which may produce some issues in the mapping world). Press <Enter> to accept viii.

viii) Finish this part by pressing the OK-icon and <save>-button
 ix) Choose ref-point object, or put in new values according to: (this is a reference point which may be north, for example)

1. Tap in the point name
2. Tap in the point-code (arbitrary)
3. Tap in the height, put this to zero.
4. Tap in bearing, if north 0, if south 180
5. As method, choose angle and distance
6. Press on the button <Measure> when all the values are entered.
 Now the S7 will perform a measurement which means the prism and S7 must be positioned correctly.
7. Press <Save> to finish the Establishment of total station.

8. Press on the instrument icon (menu, not the instrument symbol top right) and choose data output. Data output must be done with continuous output and user configured GDM-labels:

For right-handed output:

GDM label 1 (E) 38=<X coord>
 GDM label 2 (N) 37=<Y coord>
 GDM label 3 (ELE) 39=<Z coord>

- Choose com1
- Baud rate: at least 19200
- 8 data-bits
- No parity
- No stop bits
 - No flow-control

IMPORTANT: DATA STREAM MUST BE SET TO CONTINUOUS

Start the S7 data collection by select <Menu> in the right low corner. If you don't go through this button the data output will be in gon (angle and distance).

- a) Press on the measurement icon
- b) Choose continuous detail survey
- c) Choose time interval at least 100 sec

9. Press the start icon

10. Start the Talon software and choose correct total station settings according to 9) above

11. If everything works, the Position-button, on main screen

10 Appendix 6: Firewall Settings

To allow Talon-2 to operate properly, the firewall must permit UDP traffic to and from Talon-2.

These instructions describe how to configure Windows Defender Firewall in Windows 11. Other firewall software may use different procedures, which are not covered in this manual.

1. Open the Windows Firewall application.
 - a. Go to Start → Windows Security → Firewall & network protection as shown in Figure 49.
 - b. In the firewall settings window, select Advanced settings.
 - c. Confirm any prompts to open the advanced firewall settings.

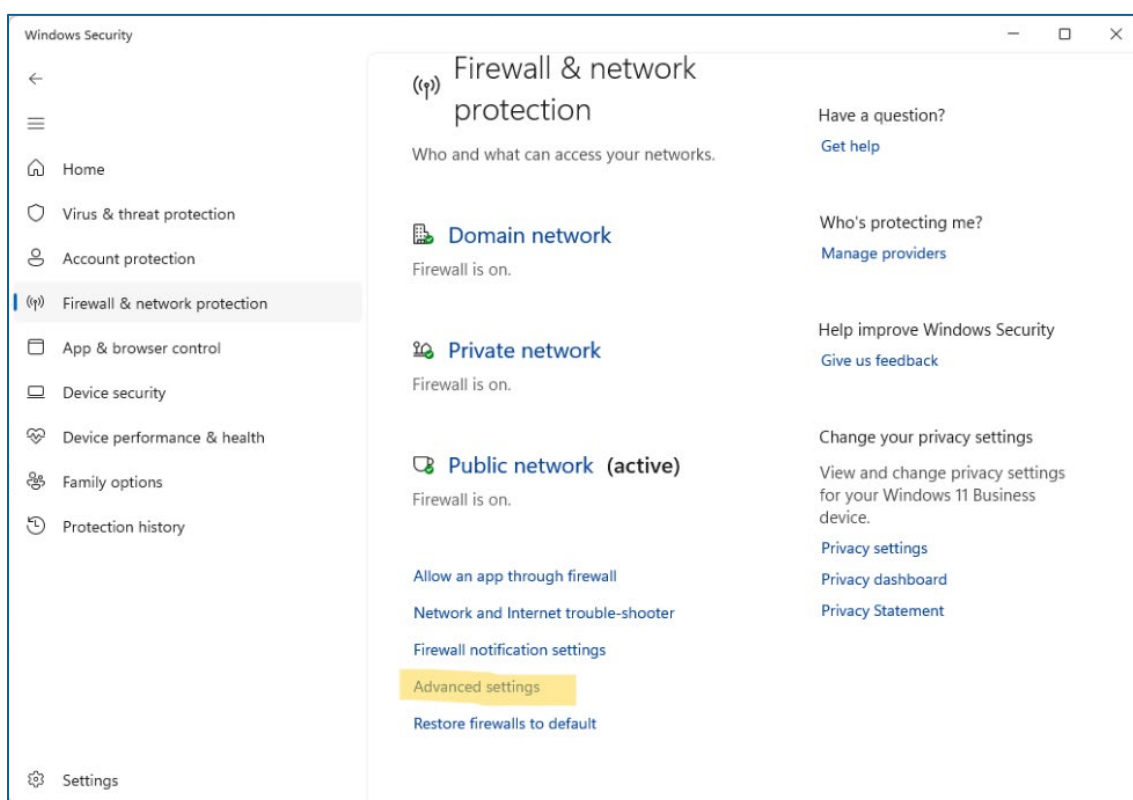

Figure 49 Windows Security firewall settings showing Firewall & network protection and access to advanced settings.

2. In the firewall settings, allow the Talon-2 application to receive UDP traffic on ports 1365, 1366, and 1367. To do so:
 - a. Select Inbound Rules. A list of firewall rules will be displayed. Locate the Talon-2 application (it may appear as talon.exe). Talon-3 (not released at the time of writing this text) may appear in the firewall application as Talon WPF as shown in Figure 50.

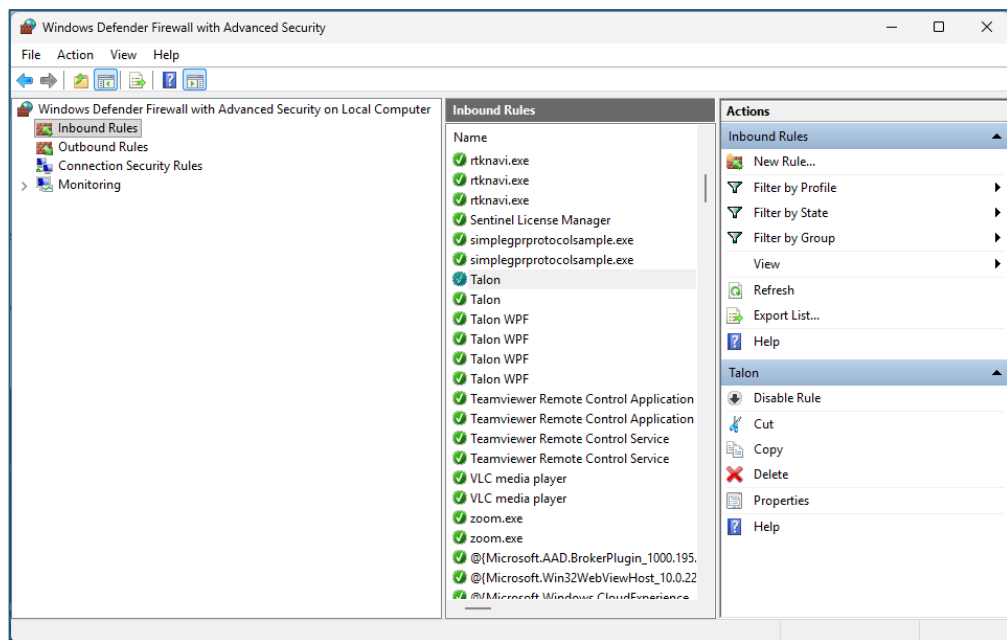

Figure 50 Windows Defender Firewall with Advanced Security showing inbound rules for Talon applications.

- b. Some Windows versions may contain multiple Talon firewall entries. Ensure that all entries are enabled (indicated by a green check mark in Figure 51). If an entry is not enabled, its settings must be modified. Repeat the following steps for each Talon entry if multiple entries exist. To modify the settings for the Talon-2 application, double-click the corresponding entry.
 - i. Ensure that the connection is set to Allow the connection as shown below in Figure 51.

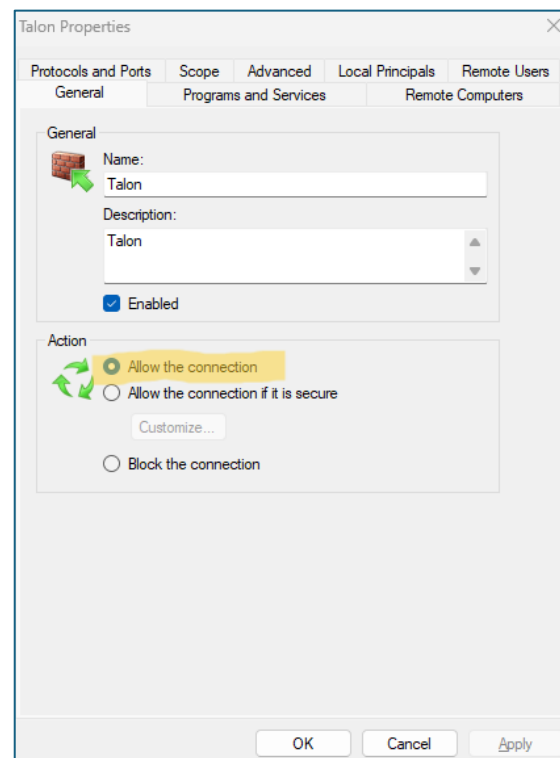

Figure 51 Talon firewall rule properties with the connection set to Allow the connection.

- ii. Verify that the protocol is set to UDP (Figure 52) and that ports 1365–1367 are allowed. If the selected entry uses TCP, close the settings window and check the next Talon entry instead.

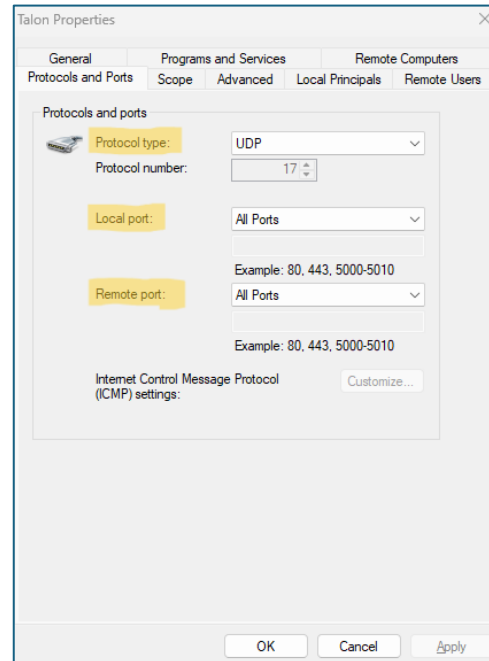

Figure 52 Talon firewall rule configured to use the UDP protocol.

- iii. Ensure that all network profiles are enabled as shown in Figure 53.

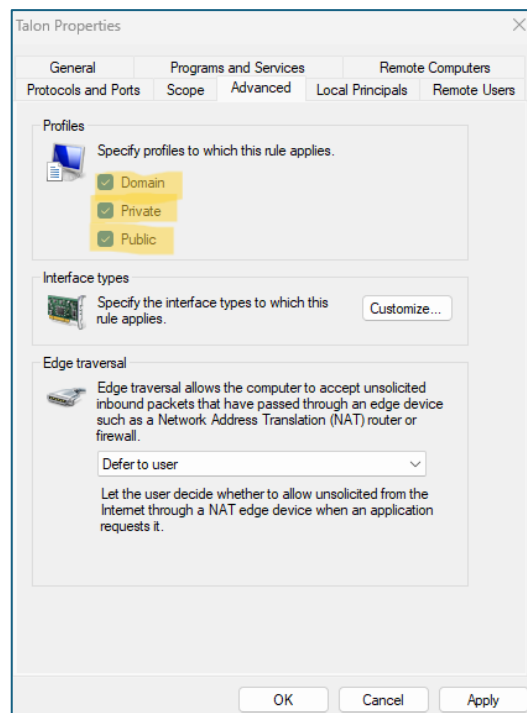

Figure 53 Talon firewall rule with all network profiles enabled.

- iv. Click **OK** to save the changes and close the settings window.

- v. Repeat the procedure for all remaining Talon entries. No firewall rule for Talon should be set to Deny. A deny rule overrides all allow rules and will block Talon communication.
3. In the Windows Firewall with Advanced Security window, note the active network profile (for example in Figure 54, Public). Click **Windows Defender Firewall Properties**.

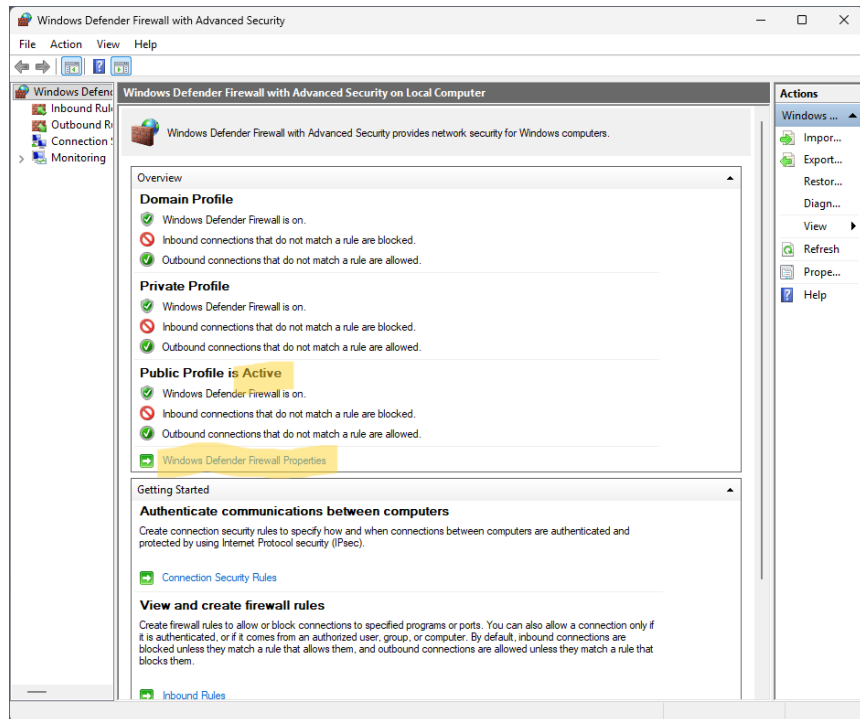

Figure 54 Windows Defender Firewall with Advanced Security showing the active public profile and access to firewall properties.

- a. Open the active profile tab (for example, **Public Profile**) and click **Customize** under **Settings**. Figure 55.

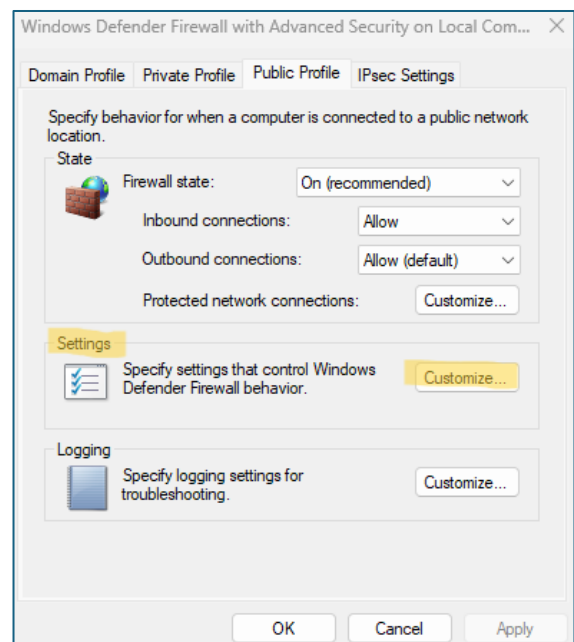

Figure 55 Windows Defender Firewall Public Profile settings with access to customized firewall behaviour settings.

- b. Ensure that local firewall rules are allowed as shown in Figure 56. If firewall settings are controlled by another source (such as Group Policy), the rules must be changed there instead. In this case, contact the network administrator to allow Talon-2 communication through the firewall.

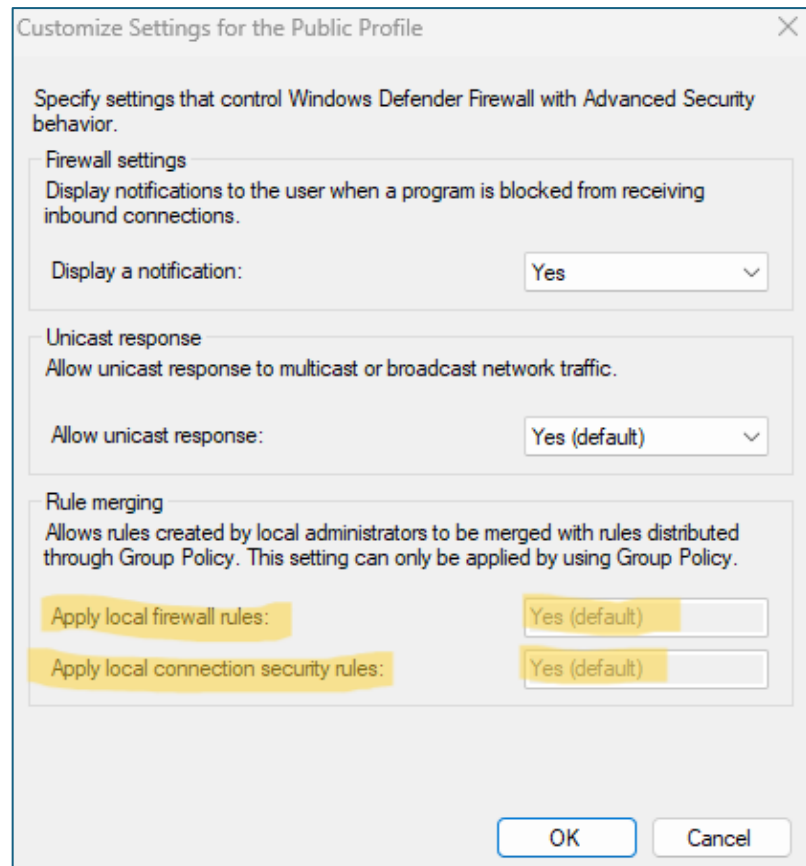

Figure 56 Customized Public Profile settings showing local firewall and connection security rules enabled.